

Model 2410 1100 V SourceMeter® Instrument

Service Manual

2410-902-01C / April 2017



2410-902-01C

Model 2410 1100V SourceMeter® Service Manual

© Keithley Instruments, Inc.
All rights reserved.
Cleveland, Ohio, U.S.A.
Third Printing, April 2017 Document
Number: 2410-902-01 Rev. C

Manual Print History

The print history shown below lists the printing dates of all Revisions and Addenda created for this manual. The Revision Level letter increases alphabetically as the manual undergoes subsequent updates. Addenda, which are released between Revisions, contain important change information that the user should incorporate immediately into the manual. Addenda are numbered sequentially. When a new Revision is created, all Addenda associated with the previous Revision of the manual are incorporated into the new Revision of the manual. Each new Revision includes a revised copy of this print history page.

Revision A (Document Number 2410-902-01).....	February 1997
Addendum A (Document Number 2410-902-02)	April 1997
Revision B (Document Number 2410-902-01)	July 1998
Revision C(Document Number 2410-902-01)	April 2017

The following safety precautions should be observed before using this product and any associated instrumentation. Although some instruments and accessories would normally be used with non-hazardous voltages, there are situations where hazardous conditions may be present.

This product is intended for use by qualified personnel who recognize shock hazards and are familiar with the safety precautions required to avoid possible injury. Read and follow all installation, operation, and maintenance information carefully before using the product. Refer to the manual for complete product specifications.

If the product is used in a manner not specified, the protection provided by the product may be impaired.

The types of product users are:

Responsible body is the individual or group responsible for the use and maintenance of equipment, for ensuring that the equipment is operated within its specifications and operating limits, and for ensuring that operators are adequately trained.

Operators use the product for its intended function. They must be trained in electrical safety procedures and proper use of the instrument. They must be protected from electric shock and contact with hazardous live circuits.

Maintenance personnel perform routine procedures on the product to keep it operating properly, for example, setting the line voltage or replacing consumable materials. Maintenance procedures are described in the manual. The procedures explicitly state if the operator may perform them. Otherwise, they should be performed only by service personnel.

Service personnel are trained to work on live circuits, and perform safe installations and repairs of products. Only properly trained service personnel may perform installation and service procedures.

Keithley products are designed for use with electrical signals that are rated Measurement Category I and Measurement Category II, as described in the International Electrotechnical Commission (IEC) Standard IEC 60664. Most measurement, control, and data I/O signals are Measurement Category I and must not be directly connected to mains voltage or to voltage sources with high transient over-voltages. Measurement Category II connections require protection for high transient over-voltages often associated with local AC mains connections. Assume all measurement, control, and data I/O connections are for connection to Category I sources unless otherwise marked or described in the Manual.

Exercise extreme caution when a shock hazard is present. Lethal voltage may be present on cable connector jacks or test fixtures. The American National Standards Institute (ANSI) states that a shock hazard exists when voltage levels greater than 30V RMS, 42.4V peak, or 60VDC are present. **A good safety practice is to expect that hazardous voltage is present in any unknown circuit before measuring.**

Operators of this product must be protected from electric shock at all times. The responsible body must ensure that operators are prevented access and/or insulated from every connection point. In some cases, connections must be exposed to potential human contact. Product operators in these circumstances must be trained to protect themselves from the risk of electric shock. If the circuit is capable of operating at or above 1000 volts, **no conductive part of the circuit may be exposed.**

Do not connect switching cards directly to unlimited power circuits. They are intended to be used with impedance limited sources. NEVER connect switching cards directly to AC mains. When connecting sources to switching cards, install protective devices to limit fault current and voltage to the card.

Before operating an instrument, make sure the line cord is connected to a properly grounded power receptacle. Inspect the connecting cables, test leads, and jumpers for possible wear, cracks, or breaks before each use.

When installing equipment where access to the main power cord is restricted, such as rack mounting, a separate main input power disconnect device must be provided, in close proximity to the equipment and within easy reach of the operator.

For maximum safety, do not touch the product, test cables, or any other instruments while power is applied to the circuit under test. ALWAYS remove power from the entire test system and discharge any capacitors before: connecting or disconnecting ca-

bles or jumpers, installing or removing switching cards, or making internal changes, such as installing or removing jumpers.

Do not touch any object that could provide a current path to the common side of the circuit under test or power line (earth) ground. Always make measurements with dry hands while standing on a dry, insulated surface capable of withstanding the voltage being measured.

The instrument and accessories must be used in accordance with its specifications and operating instructions or the safety of the equipment may be impaired.

Do not exceed the maximum signal levels of the instruments and accessories, as defined in the specifications and operating information, and as shown on the instrument or test fixture panels, or switching card.

When fuses are used in a product, replace with same type and rating for continued protection against fire hazard.

Chassis connections must only be used as shield connections for measuring circuits, NOT as safety earth ground connections.

If you are using a test fixture, keep the lid closed while power is applied to the device under test. Safe operation requires the use of a lid interlock.

If a  screw is present, connect it to safety earth ground using the wire recommended in the user documentation.

The  symbol on an instrument indicates that the user should refer to the operating instructions located in the manual.

The  symbol on an instrument shows that it can source or measure 1000 volts or more, including the combined effect of normal and common mode voltages. Use standard safety precautions to avoid personal contact with these voltages.

The  symbol indicates a connection terminal to the equipment frame.

The **WARNING** heading in a manual explains dangers that might result in personal injury or death. Always read the associated information very carefully before performing the indicated procedure.

The **CAUTION** heading in a manual explains hazards that could damage the instrument. Such damage may invalidate the warranty.

Instrumentation and accessories shall not be connected to humans.

Before performing any maintenance, disconnect the line cord and all test cables.

To maintain protection from electric shock and fire, replacement components in mains circuits, including the power transformer, test leads, and input jacks, must be purchased from Keithley Instruments. Standard fuses, with applicable national safety approvals, may be used if the rating and type are the same. Other components that are not safety related may be purchased from other suppliers as long as they are equivalent to the original component. (Note that selected parts should be purchased only through Keithley Instruments to maintain accuracy and functionality of the product.) If you are unsure about the applicability of a replacement component, call a Keithley Instruments office for information.

To clean an instrument, use a damp cloth or mild, water based cleaner. Clean the exterior of the instrument only. Do not apply cleaner directly to the instrument or allow liquids to enter or spill on the instrument. Products that consist of a circuit board with no case or chassis (e.g., data acquisition board for installation into a computer) should never require cleaning if handled according to instructions. If the board becomes contaminated and operation is affected, the board should be returned to the factory for proper cleaning/servicing.

Table of Contents

1 Performance Verification

Introduction.....	1-2
Verification test requirements.....	1-3
Restoring factory defaults.....	1-6
Performing the verification test procedures.....	1-7
Compliance considerations.....	1-9
Output voltage accuracy.....	1-11
Voltage measurement accuracy.....	1-13
Output current accuracy.....	1-14
Current measurement accuracy.....	1-16
Resistance measurement accuracy.....	1-17

2 Calibration

Introduction.....	2-2
Environmental conditions.....	2-3
Calibration considerations.....	2-4
Front panel calibration.....	2-9
Remote calibration.....	2-16
Single-range calibration.....	2-24

3 Routine Maintenance

Introduction.....	3-2
Line fuse replacement.....	3-2

4 Troubleshooting

Introduction.....	4-2
Repair considerations.....	4-2
Power-on self-test.....	4-2
Front panel tests.....	4-3
Principles of operation.....	4-5
Troubleshooting.....	4-13
Analog circuitry checks.....	4-16
Battery replacement.....	4-17
No comm link error.....	4-18

5 Disassembly

Introduction	5-2
Handling and cleaning.....	5-2
Static sensitive devices.....	5-3
Assembly drawings	5-4
Case cover removal	5-5
Analog board removal.....	5-6
Digital board removal.....	5-7
Front panel disassembly	5-8
Removing power components	5-9
Instrument re-assembly	5-10

6 Replaceable Parts

Introduction	6-2
Parts lists	6-2
Ordering information.....	6-2
Factory service	6-3
Component layouts.....	6-3

A Specifications

Accuracy calculations	A-2
-----------------------------	-----

B Command Reference

Introduction	B-2
Command summary	B-2
Miscellaneous commands	B-3
Detecting calibration errors.....	B-11
Detecting calibration step completion.....	B-13

C Calibration Programs

Introduction	C-2
Computer hardware requirements	C-2
Software requirements.....	C-2
Calibration equipment.....	C-3
General program instructions	C-3
Requesting calibration constants	C-7

List of Illustrations

1 Performance Verification

Connections for voltage verification tests	1-12
Connections for current verification tests	1-15
Connections for resistance accuracy verification	1-18

2 Calibration

Voltage calibration test connections	2-11
Current calibration test connections	2-13

3 Routine Maintenance

Rear panel	3-3
------------------	-----

4 Troubleshooting

Overall block diagram	4-5
Analog circuitry block diagram	4-7
Power supply block diagram	4-8
Output stage simplified schematic	4-9
Digital circuitry block diagram	4-11

List of Tables

1 Performance Verification

Recommended verification equipment.....	1-4
Output voltage accuracy limits.....	1-11
Voltage measurement accuracy limits.....	1-13
Output current accuracy limits.....	1-14
Current measurement accuracy limits.....	1-16
Ohms measurement accuracy limits.....	1-18

2 Calibration

Recommended calibration equipment.....	2-5
Calibration unlocked states.....	2-6
Front panel voltage calibration.....	2-11
Front panel current calibration.....	2-14
Remote calibration command summary.....	2-16
Recommended :CALibration:PROTeCted:SENSe.....	2-17
parameter ranges	
Recommended :CALibration:PROTeCted:SOURce.....	2-18
parameter ranges	
Voltage calibration initialization commands.....	2-20
Voltage range calibration commands.....	2-20
Current calibration initialization commands.....	2-22
Current range calibration commands.....	2-22

3 Routine Maintenance

Power line fuse.....	3-2
----------------------	-----

4 Troubleshooting

Display board checks.....	4-13
Power supply checks.....	4-14
Digital circuitry checks.....	4-15
Analog circuitry checks.....	4-16

6 Replaceable Parts

Analog board parts list.....	6-4
Digital board parts list.....	6-11
Display board parts list.....	6-14
Mechanical parts list.....	6-15

B Command Reference

Remote calibration command summary	B-2
Recommended :CALibration:PROTected:SENSe	B-7
parameter ranges	
Recommended :CALibration:PROTected:SOURce.....	B-9
parameter ranges	
Calibration errors	B-12

1 Performance Verification

Introduction

Use the procedures in this section to verify that Model 2410 accuracy is within the limits stated in the instrument's one-year accuracy specifications. You can perform these verification procedures:

- When you first receive the instrument to make sure it was not damaged during shipment.
- To verify that the unit meets factory specifications.
- To determine if calibration is required.
- Following calibration to make sure it was performed properly.

WARNING **The information in this section is intended for qualified service personnel only. Do not attempt these procedures unless you are qualified to do so. Some of these procedures may expose you to hazardous voltages, which could cause personal injury or death if contacted. Use standard safety precautions when working with hazardous voltages.**

NOTE *If the instrument is still under warranty and its performance is outside specified limits, contact your Keithley representative or the factory to determine the correct course of action.*

Verification test requirements

Be sure that you perform the verification tests:

- Under the proper environmental conditions.
- After the specified warm-up period.
- Using the correct line voltage.
- Using the proper test equipment.
- Using the specified output signal and reading limits.

Environmental conditions

Conduct your performance verification procedures in a test environment with:

- An ambient temperature of 18-28°C.
- A relative humidity of less than 70% unless otherwise noted.

Warm-up period

Allow the Model 2410 to warm up for at least one hour before conducting the verification procedures. If the instrument has been subjected to temperature extremes (those outside the ranges stated above), allow additional time for the instrument's internal temperature to stabilize. Typically, allow one extra hour to stabilize a unit that is 10°C outside the specified temperature range.

Also, allow the test equipment to warm up for the minimum time specified by the manufacturer.

Line power

The Model 2410 requires a line voltage of 100 to 240V and a line frequency of 50 Hz to 60 Hz. Verification tests must be performed within this range.

Recommended test equipment

Table 1-1 summarizes recommended verification equipment. You can use alternate equipment if that equipment has specifications at least as good as those listed in Table 1-1. Be aware, however, that test equipment uncertainty will add to the uncertainty of each measurement. Generally, test equipment uncertainty should be at least four times better than corresponding Model 2410 specifications. Table 1-1 lists the uncertainties of the recommended test equipment including the maximum allowable uncertainty of alternate test equipment shown in parentheses.

Table 1-1
Recommended verification equipment

Description	Manufacturer/ Model	Accuracy
Digital multimeter	Hewlett Packard HP3458A	DC voltage* 1V: ±5.6ppm 10V: ±4.3ppm 100V: ±6.3ppm 1000V: ±6.1ppm DC current* 1μA: ±55ppm 10μA: ±25ppm 100μA: ±23ppm 1mA: ±20ppm 100mA: ±35ppm 1A: ±110ppm
Resistance calibrator	Fluke 5450A	Resistance** 19Ω: ±23ppm (±340ppm) 190Ω: ±10.5ppm (±370ppm) 1.9kΩ: ±8ppm (±265ppm) 19kΩ: ±7.5ppm (±250ppm) 190kΩ: ±8.5ppm (±260ppm) 1.9MΩ: ±11.5ppm (±365ppm) 19MΩ: ±30ppm (±315ppm) 100MΩ: ±120ppm (±1700ppm)

* 90-day full-scale accuracy specifications of ranges required for various measurement points.

** 90-day specifications of nominal resistance values shown. Maximum uncertainty of alternate test equipment is shown in parentheses.

Verification limits

The verification limits stated in this section have been calculated using only the Model 2410 one-year accuracy specifications, and they do not include test equipment uncertainty. If a particular measurement falls outside the allowable range, recalculate new limits based both on Model 2410 specifications and corresponding test equipment specifications.

Example limits calculation

As an example of how verification limits are calculated, assume you are testing the 20V DC output range using a 20V output value. Using the Model 2410 one-year accuracy specification for 20V DC output of $\pm(0.02\%$ of output + 2.4mV offset), the calculated output limits are:

$$\text{Output limits} = 20\text{V} \pm [(20\text{V} \times 0.02\%) + 2.4\text{mV}]$$

$$\text{Output limits} = 20\text{V} \pm (0.004 + 0.0024)$$

$$\text{Output limits} = 20\text{V} \pm 0.0064\text{V}$$

$$\text{Output limits} = 19.9936\text{V to } 20.0064\text{V}$$

Resistance limits calculation

When verifying the ohms function, it will probably be necessary to recalculate resistance limits based on the actual calibrator resistance values. You can calculate resistance reading limits in the same manner described above. Be sure to use the actual calibrator resistance values and the Model 2410 normal accuracy specifications for your calculations.

As an example, assume that you are testing the 20k Ω range and that the actual value of the nominal 19k Ω calibrator resistor is 19.025k Ω . Using the Model 2410 one-year normal accuracy specifications of $\pm(0.07\%$ of reading + 6 Ω), the recalculated reading limits are:

$$\text{Reading limits} = 19.025\text{k}\Omega \pm [(19.025\text{k}\Omega \times 0.07\%) + 6\Omega]$$

$$\text{Reading limits} = 19.025\text{k}\Omega \pm 19.3\Omega$$

$$\text{Reading limits} = 19.0057\text{k}\Omega \text{ to } 19.0443\text{k}\Omega$$

Restoring factory defaults

Before performing the verification procedures, restore the instrument to its factory front panel (bench) defaults as follows:

1. Press the MENU key. The instrument will display the following prompt:
MAIN MENU
SAVESETUP COMMUNICATION CAL ►
2. Select SAVESETUP, and then press ENTER. The unit displays:
SAVESETUP MENU
GLOBAL SOURCE-MEMORY
3. Select GLOBAL, and then press ENTER. The unit then displays:
GLOBAL SETUP MENU
SAVE RESTORE POWERON RESET
4. Select RESET, and then press ENTER. The unit displays:
RESET ORIGINAL DFLTS
BENCH GPIB
5. Select BENCH, and then press ENTER. The unit then displays:
RESETTING INSTRUMENT
ENTER to confirm; EXIT to abort
6. Press ENTER to restore bench defaults, and note the unit displays the following:
RESET COMPLETE
BENCH defaults are now restored ►
◀ Press ENTER to continue
7. Press ENTER and then EXIT as necessary to return to normal display.

Performing the verification test procedures

Test summary

- DC voltage output accuracy
- DC voltage measurement accuracy
- DC current output accuracy
- DC current measurement accuracy
- Resistance measurement accuracy

If the Model 2410 is not within specifications and not under warranty, see the calibration procedures in Section 2 for information on calibrating the unit.

Test considerations

When performing the verification procedures:

- Be sure to restore factory front panel defaults as outlined above.
- Make sure the test equipment is properly warmed up and connected to the Model 2410 INPUT/OUTPUT jacks. Also be sure that the front panel jacks are selected with the TERMINALS key.
- Make sure the Model 2410 is set to the correct source range.
- Be sure the Model 2410 output is turned on before making measurements.
- Be sure the test equipment is set up for the proper function and range.
- Allow the Model 2410 output signal to settle before making a measurement.
- Do not connect test equipment to the Model 2410 through a scanner, multiplexer, or other switching equipment.

WARNING **The maximum common-mode voltage (voltage between LO and chassis ground) is 250V peak. Exceeding this value may cause a breakdown in insulation, creating a shock hazard.**

CAUTION **The maximum voltage between INPUT/OUTPUT HI and LO or 4-WIRE SENSE HI and LO is 1100V peak. The maximum voltage between INPUT/OUTPUT HI and 4-WIRE SENSE HI or between INPUT/OUTPUT LO and 4-WIRE SENSE LO is 5V. Exceeding these voltage values may result in instrument damage.**

Setting the source range and output value

Before testing each verification point, you must properly set the source range and output value as outlined below.

1. Press either the SOURCE V or SOURCE I key to select the appropriate source function.
2. Press the EDIT key as required to select the source display field. Note that the cursor will flash in the source field while its value is being edited.
3. With the cursor in the source display field flashing, set the source range to the lowest possible range for the value to be sourced using the up or down RANGE key. For example, you should use the 20V source range to output a 20V source value. With a 20V source value and the 20V range selected, the source field display will appear as follows:
Vsrc:+20.0000 V
4. With the source field cursor flashing, set the source output to the required value using either:
 - The SOURCE adjustment and left and right arrow keys.
 - The numeric keys.
5. Note that the source output value will be updated immediately. You need not press ENTER when setting the source value.

Setting the measurement range

When simultaneously sourcing and measuring either voltage or current, the measure range is coupled to the source range, and you cannot independently control the measure range. Thus, it is not necessary for you to set the range when testing voltage or current measurement accuracy.

Compliance considerations

Compliance limits

When sourcing voltage, you can set the SourceMeter to limit current from 1nA to 1.05A. Conversely, when sourcing current, you can set the SourceMeter to limit voltage from 200 μ V to 1.1kV. The SourceMeter output will not exceed the programmed compliance limit.

Types of compliance

There are two types of compliance that can occur: Real and range. Depending upon which value is lower, the output will clamp at either the displayed compliance setting (real) or at the maximum measurement range reading (range).

The real compliance condition can occur when the compliance setting is less than the highest possible reading of the measurement range. When in compliance, the source output clamps at the displayed compliance value. For example, if the compliance voltage is set to 1V and the measurement range is 2V, the output voltage will clamp (limit) at 1V.

Range compliance can occur when the compliance setting is higher than the possible reading of the selected measurement range. When in compliance, the source output clamps at the maximum measurement range reading (not the compliance value). For example, if the compliance voltage is set to 1V and the measurement range is 200mV, the output voltage will clamp (limit) at 210mV.

Determining compliance limit

The relationships to determine which compliance is in effect are summarized as follows. They assume the measurement function is the same as the compliance function.

- Compliance Setting < Measurement Range = Real Compliance
- Measurement Range < Compliance Setting = Range Compliance

You can determine the compliance that is in effect by comparing the displayed compliance setting to the present measurement range. If the compliance setting is lower than the maximum possible reading on the present measurement range, the compliance setting is the compliance limit. If the compliance setting is higher than the measurement range, the maximum reading on that measurement range is the compliance limit.

Taking the SourceMeter out of compliance

Verification measurements should not be made when the SourceMeter is in compliance. For purposes of the verification tests, the SourceMeter can be taken out of compliance by going into the edit mode and increasing the compliance limit.

NOTE *Do not take the unit out of compliance by decreasing the source value or changing the range. Always use the recommended range and source settings when performing the verification tests.*

Output voltage accuracy

Follow the steps below to verify that Model 2410 output voltage accuracy is within specified limits. This test involves setting the output voltage to each full-range value and measuring the voltages with a precision digital multimeter.

1. With the power off, connect the digital multimeter to the Model 2410 INPUT/OUTPUT jacks as shown in Figure 1-1.
2. Select the multimeter DC volts measuring function.
3. Set the voltage source protection to >1100V. To do so, press CONFIG and then SOURCE V-SOURCE menu to access the CONFIGURE V-SOURCE menu. Then select PROTECTION, and set the voltage source protection limit to >1100V.
4. Press the Model 2410 SOURCE V key to source voltage, and make sure the source output is turned on.
5. Verify output voltage accuracy for each of the voltages listed in Table 1-2. For each test point:
 - Select the correct source range.
 - Set the Model 2410 output voltage to the indicated value.
 - Verify that the multimeter reading is within the limits given in the table.
6. Repeat the procedure for negative output voltages with the same magnitude as those listed in Table 1-2.
7. Repeat the entire procedure using the rear panel INPUT/OUTPUT jacks. Be sure to select the rear panel jacks with the front panel TERMINALS key.

Table 1-2
Output voltage accuracy limits

Model 2410 source range	Model 2410 output voltage setting	Output voltage limits (1 year, 18°C–28°C)
200mV	200.000mV	199.360 to 200.640mV
2V	2.00000V	1.99900 to 2.00100V
20V	20.0000V	19.9936 to 20.0064V
1000V	975.00V	974.705 to 975.295V

Figure 1-1
Connections for voltage
verification tests

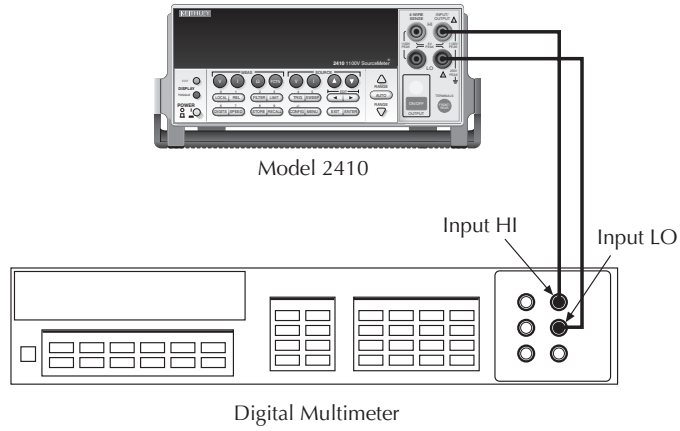

Voltage measurement accuracy

Follow the steps below to verify that the Model 2410 voltage measurement accuracy is within specified limits. The test involves setting the source voltage to full-range values, as measured by a precision digital multimeter, and then verifying that the Model 2410 voltage readings are within required limits.

1. With the power off, connect the digital multimeter to the Model 2410 INPUT/OUTPUT jacks as shown in Figure 1-1.
2. Select the multimeter DC volts function.
3. Set the voltage source protection to >1100V. To do so, press CONFIG then SOURCE V to access the CONFIGURE V-SOURCE menu, then select PROTECTION, and set the voltage source protection limit to >1100V.
4. Set the Model 2410 to both source and measure voltage by pressing the SOURCE V and MEAS V keys, and make sure the source output is turned on.
5. Verify output voltage accuracy for each of the voltages listed in Table 1-3. For each test point:
 - Select the correct source range.
 - Set the Model 2410 output voltage to the indicated value as measured by the digital multimeter.
 - Verify that the Model 2410 voltage reading is within the limits given in the table.

NOTE *It may not be possible to set the voltage source to the specified value. Use the closest possible setting, and modify reading limits accordingly.*

6. Repeat the procedure for negative source voltages with the same magnitudes as those listed in Table 1-3.
7. Repeat the entire procedure using the rear panel INPUT/OUTPUT jacks. Be sure to select the rear panel jacks with the front panel TERMINALS key.

Table 1-3
Voltage measurement accuracy limits

Model 2410 source and measure range*	Source voltage**	Model 2410 voltage reading limits (1 year, 18°C–28°C)
200mV	200.000mV	199.676 to 200.324mV
2V	2.00000V	1.99946 to 2.00054V
20V	20.0000V	19.9960 to 20.0040V
1000V	975.00V	974.80 to 975.20V

* Measure range coupled to source range when simultaneously sourcing and measuring voltage.

** As measured by precision digital multimeter. Use closest possible value, and modify reading limits accordingly if necessary.

Output current accuracy

Follow the steps below to verify that Model 2410 output current accuracy is within specified limits. The test involves setting the output current to each full-range value and measuring the currents with a precision digital multimeter.

1. With the power off, connect the digital multimeter to the Model 2410 INPUT/OUTPUT jacks as shown in Figure 1-2.
2. Select the multimeter DC current measuring function.
3. Press the Model 2410 SOURCE I key to source current, and make sure the source output is turned on.
4. Verify output current accuracy for each of the currents listed in Table 1-4. For each test point:
 - Select the correct source range.
 - Set the Model 2410 output current to the correct value.
 - Verify that the multimeter reading is within the limits given in the table.
5. Repeat the procedure for negative output currents with the same magnitudes as those listed in Table 1-4.
6. Repeat the entire procedure using the rear panel INPUT/OUTPUT jacks. Be sure to select the rear panel jacks with the front panel TERMINALS key.

Table 1-4

Output current accuracy limits

Model 2410 source range	Model 2410 output current setting	Output current limits (1 year, 18°C–28°C)
1μA	1.00000μA	0.99905 to 1.00095μA
10μA	10.0000μA	9.9947 to 10.0053μA
100μA	100.000μA	99.949 to 100.051μA
1mA	1.00000mA	0.99946 to 1.00054mA
20mA	20.0000mA	19.9870 to 20.0130mA
100mA	100.000mA	99.914 to 100.086mA
1A	1.00000A	0.99640 to 1.00360A

Figure 1-2
Connections for
current verification
tests

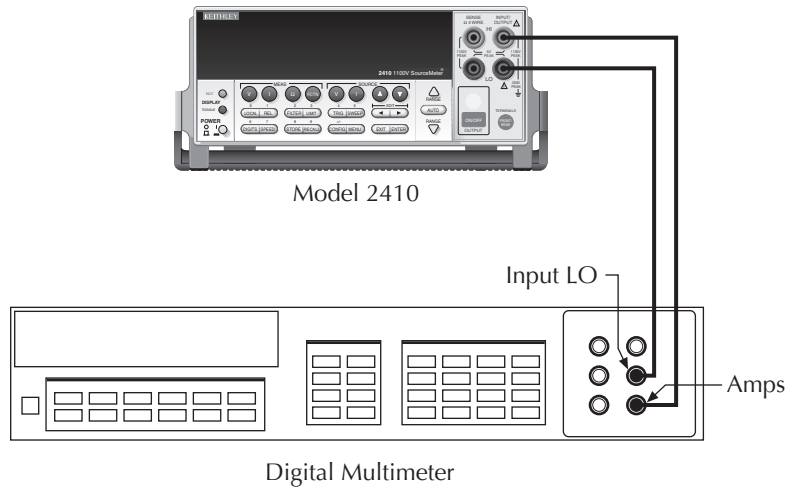

Current measurement accuracy

Follow the steps below to verify that Model 2410 current measurement accuracy is within specified limits. The procedure involves applying accurate currents from the Model 2410 current source and then verifying that Model 2410 current measurements are within required limits.

1. With the power off, connect the digital multimeter to the Model 2410 INPUT/OUTPUT jacks as shown in Figure 1-2.
2. Select the multimeter DC current function.
3. Set the Model 2410 to both source and measure current by pressing the SOURCE I and MEAS I keys, and make sure the source output is turned on.
4. Verify measure current accuracy for each of the currents listed in Table 1-5. For each measurement:
 - Select the correct source range.
 - Set the Model 2410 source output to the correct value as measured by the digital multimeter.
 - Verify that the Model 2410 current reading is within the limits given in the table.

NOTE *It may not be possible to set the current source to the specified value. Use the closest possible setting, and modify reading limits accordingly.*

5. Repeat the procedure for negative calibrator currents with the same magnitudes as those listed in Table 1-5.
6. Repeat the entire procedure using the rear panel INPUT/OUTPUT jacks. Be sure to select the rear panel jacks with the front panel TERMINALS key.

Table 1-5
Current measurement accuracy limits

Model 2410 source and measure range*	Source current**	Model 2410 current reading limits (1 year, 18°C–28°C)
1μA	1.00000μA	0.99941 to 1.00059μA
10μA	10.0000μA	9.9966 to 10.0034μA
100μA	100.000μA	99.969 to 100.031μA
1mA	1.00000mA	0.99967 to 1.00033mA
20mA	20.0000mA	19.9918 to 20.0082mA
100mA	100.000mA	99.939 to 100.061mA
1A	1.00000A	0.99723 to 1.00277A

* Measure range coupled to source range when simultaneously sourcing and measuring current.

** As measured by precision digital multimeter. Use closest possible value, and modify reading limits accordingly if necessary.

Resistance measurement accuracy

Follow the steps below to verify that Model 2410 resistance measurement accuracy is within specified limits. This procedure involves applying accurate resistances from a resistance calibrator and then verifying that Model 2410 resistance measurements are within required limits.

1. With the power off, connect the resistance calibrator to the Model 2410 INPUT/OUTPUT and 4-WIRE SENSE jacks as shown in Figure 1-3. Be sure to use the four-wire connections as shown.
2. Select the resistance calibrator external sense mode.
3. Configure the Model 2410 ohms function for the 4-wire sense mode as follows:
 - Press CONFIG then MEAS Ω . The instrument will display the following: CONFIG
OHMS
SOURCE SENSE-MODE GUARD
 - Select SENSE-MODE, and then press ENTER. The following will be displayed:
SENSE-MODE
2-WIRE 4-WIRE
 - Select 4-WIRE, and then press ENTER.
 - Press EXIT to return to normal display.
4. Press MEAS Ω to select the ohms measurement function, and make sure the source out-put is turned on.
5. Verify ohms measurement accuracy for each of the resistance values listed in Table 1-6. For each measurement:
 - Set the resistance calibrator output to the nominal resistance or closest available value.

NOTE *It may not be possible to set the resistance calibrator to the specified value. Use the closest possible setting, and modify reading limits accordingly.*

- Select the appropriate ohms measurement range with the RANGE keys.
 - Verify that the Model 2410 resistance reading is within the limits given in the table.
6. Repeat the entire procedure using the rear panel INPUT/OUTPUT and 4-WIRE SENSE jacks. Be sure to select the rear panel jacks with the front panel TERMINALS key.

Table 1-6
Ohms measurement accuracy limits

Model 2410 range	Calibrator resistance*	Model 2410 resistance reading limits** (1 year, 18°C–28°C)
20Ω	19Ω	18.9731 to 19.0269Ω
200Ω	190Ω	189.709 to 190.291Ω
2kΩ	1.9kΩ	1.89788 to 1.90212kΩ
20kΩ	19kΩ	18.9807 to 19.0212kΩ
200kΩ	190kΩ	189.807 to 190.193kΩ
2MΩ	1.9MΩ	1.89712 to 1.90288MΩ
20MΩ	19MΩ	18.9748 to 19.0252MΩ
200MΩ	100MΩ	99.316 to 100.684MΩ

* Nominal resistance value.

** Reading limits based on Model 2410 normal accuracy specifications and nominal resistance values. If actual resistance values differ from nominal values shown, recalculate reading limits using actual calibrator resistance values and Model 2410 normal accuracy specifications. See verification limits earlier in this section for details.

Figure 1-3
Connections for resistance accuracy verification

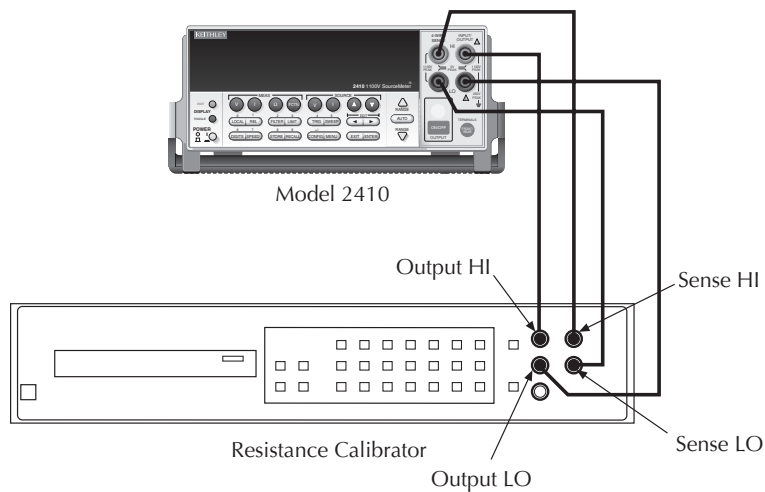

2 Calibration

Introduction

Use the procedures in this section to calibrate the Model 2410. These procedures require accurate test equipment to measure precise DC voltages and currents. Calibration can be performed either from the front panel, or by sending SCPI calibration commands over the IEEE-488 bus or RS-232 port with the aid of a computer.

WARNING **The information in this section is intended for qualified service personnel only. Do not attempt these procedures unless you are qualified to do so. Some of these procedures may expose you to hazardous voltages.**

Environmental conditions

Temperature and relative humidity

Conduct the calibration procedures at an ambient temperature of 18-28°C with relative humidity of less than 70% unless otherwise noted.

Warm-up period

Allow the Model 2410 to warm up for at least one hour before performing calibration.

If the instrument has been subjected to temperature extremes (those outside the ranges stated above), allow additional time for the instrument's internal temperature to stabilize. Typically, allow one extra hour to stabilize a unit that is 10°C (18°F) outside the specified temperature range.

Also, allow the test equipment to warm up for the minimum time specified by the manufacturer.

Line power

The Model 2410 requires a line voltage of 100 to 240V at line frequency of 50 to 60Hz. The instrument must be calibrated within this range.

Calibration considerations

When performing the calibration procedures:

- Make sure that the test equipment is properly warmed up and connected to the Model 2410 front panel INPUT/OUTPUT jacks. Also be certain that the front panel jacks are selected with the TERMINALS switch.
- Always allow the source signal to settle before calibrating each point.
- Do not connect test equipment to the Model 2410 through a scanner or other switching equipment.
- If an error occurs during calibration, the Model 2410 will generate an appropriate error message. See Appendix B for more information.

WARNING **The maximum common-mode voltage (voltage between LO and chassis ground) is 250V peak. Exceeding this value may cause a breakdown in insulation, creating a shock hazard.**

CAUTION **The maximum voltage between INPUT/OUTPUT HI and LO or 4-WIRE SENSE HI and LO is 1100V peak. The maximum voltage between INPUT/OUTPUT HI and 4-WIRE SENSE HI or between INPUT/OUTPUT LO and 4-WIRE SENSE LO is 5V. Exceeding these voltage values may result in instrument damage.**

Calibration cycle

Perform calibration at least once a year to ensure the unit meets or exceeds its specifications.

NOTE *Calibration constants are stored in volatile memories of the Model 2410, which are protected by a replaceable battery when power is off. Typical life for the battery is approximately 10 years, but the battery should be replaced if the voltage drops below 2.5V regardless of age. See Section 4 for battery replacement details.*

Recommended calibration equipment

Table 2-1 lists the recommended equipment for the calibration procedures. You can use alternate equipment as long as that equipment has specifications at least as good as those listed in the table. Where possible, test equipment specifications should be at least four times better than corresponding Model 2410 specifications.

Table 2-1
Recommended calibration equipment

Description	Manufacturer/ Model	Accuracy*
Digital Multimeter	Hewlett Packard HP3458A	DC voltage 1V: ±5.6ppm 10V: ±4.3ppm 100V: ±6.3ppm 1000V: ±6.1ppm DC current 1μA: ±55ppm 10μA: ±25ppm 100μA: ±23ppm 1mA: ±20ppm 100mA: ±35ppm 1A: ±110ppm

* 90-day, full-scale accuracy specifications of ranges required for various measurement points.

Unlocking calibration

Before performing calibration, you must first unlock calibration by entering or sending the calibration password as discussed below:

Unlocking calibration from the front panel

- Press the MENU key, then choose CAL and press ENTER. The instrument will display the following:
 CALIBRATION
 UNLOCK EXECUTE VIEW-DATES ►
 ◀ SAVE LOCK CHANGE-PASSWORD
- Select UNLOCK, and then press ENTER. The instrument will display the following:
 PASSWORD:
 Use ◀, ▶, ▲, ▼, ENTER, or EXIT.
- Use the up and down RANGE keys to select the letter or number and use the left and right arrow keys to choose the position. (Press down RANGE for letters; up RANGE for numbers.) Enter the present password on the display. (Front panel default: 002410.)

4. Once the correct password is displayed, press the ENTER key. If the password was correctly entered, the following message will be displayed:
CALIBRATION UNLOCKED
Calibration can now be executed.
5. Press EXIT to return to normal display. Calibration will be unlocked and will assume the states summarized in Table 2-2. Attempts to change any of the settings listed below with calibration unlocked will result in an error +510, "Not permitted with cal unlocked."

NOTE With calibration unlocked, the sense function and range track the source function and range. That is, when :SOUR:FUNC is set to VOLT, the :SENS:FUNC setting will be 'VOLT:DC'. When :SOUR:FUNC is set to CURR, the :SENS:FUNC setting will be 'CURR:DC'. A similar command coupling exists for :SOUR:VOLT:RANG/ :SENS:VOLT:RANG/ and SOUR:CURR:RANG/:SENS:CURR:RANG.

Table 2-2
Calibration unlocked states

Mode	State	Equivalent remote command
Concurrent Functions	OFF	:SENS:FUNC:CONC OFF
Sense Function	Source	:SENS:FUNC <source_function>
Sense Volts NPLC	1.0	:SENS:VOLT:NPLC 1.0
Sense Volts Range	Source V	:SENS:VOLT:RANG <source_V_range>
Sense Current NPLC	1.0	:SENS:CURR:NPLC 1.0
Sense Current Range	Source I	:SENS:CURR:RANG <source_I_range>
Filter Count	10	:SENS:AVER:COUN 10
Filter Control	REPEAT	:SENS:AVER:TCON REPEAT
Filter Averaging	ON	:SENS:AVER:STAT ON
Source V Mode	FIXED	:SOUR:VOLT:MODE FIXED
Volts Autorange	OFF	:VOLT:RANG:AUTO OFF
Source I Mode	FIXED	:SOUR:CURR:MODE FIXED
Current Autorange	OFF	:SOUR:CURR:RANG:AUTO OFF
Autozero	ON	:SYST:AZERO ON
Trigger Arm Count	1	:ARM:COUNT 1
Trigger Arm Source	Immediate	:ARM:SOUR IMMEDIATE
Trigger Count	1	:TRIG:COUNT 1
Trigger Source	Immediate	:TRIG:SOUR IMMEDIATE

Unlocking calibration by remote

To unlock calibration via remote, send the following command:

```
:CAL:PROT:CODE '<password>'
```

For example, the following command uses the default password:

```
:CAL:PROT:CODE 'KI002410'
```

Changing the password

The default password may be changed from the front panel or via remote as discussed below.

Changing the password from the front panel

Follow the steps below to change the password from the front panel:

1. Press the MENU key, then choose CAL and press ENTER. The instrument will display the following:
CALIBRATION
UNLOCK EXECUTE VIEW-DATES ►
◀ SAVE LOCK CHANGE-PASSWORD
2. Select UNLOCK, and then enter the password. (Default: 002410.)
3. Select CHANGE-PASSWORD, and then press ENTER. The instrument will display the following:
New Pwd: 002410
Use ◀, ▶, ▲, ▼, ENTER, or EXIT.
4. Using the range keys, and the left and right arrow keys, enter the new password on the display.
5. Once the desired password is displayed, press the ENTER key to store the new password.

Changing the password by remote

To change the calibration password by remote, first send the present password, and then send the new password. For example, the following command sequence changes the password from the 'KI002410' remote default to 'KI_CAL':

```
:CAL:PROT:CODE 'KI002410'  
:CAL:PROT:CODE 'KI_CAL'
```

You can use any combination of letters and numbers up to a maximum of eight characters.

NOTE *If you change the first two characters of the password to something other than "KI," you will not be able to unlock calibration from the front panel.*

Resetting the calibration password

If you lose the calibration password, you can unlock calibration by shorting together the CAL pads, which are located on the display board. Doing so will also reset the password to the factory default (KI002410).

See Section 5 for details on disassembling the unit to access the CAL pads. Refer to the display board component layout drawing at the end of Section 6 for the location of the CAL pads.

Viewing calibration dates and calibration count

When calibration is locked, only the UNLOCK and VIEW-DATES selections are accessible in the calibration menu. To view the calibration dates and calibration count at any time:

1. From normal display, press MENU, select CAL, and then press ENTER. The unit will display the following:

```
CALIBRATION  
UNLOCK EXECUTE VIEW-DATES ►
```

2. Select VIEW-DATES, and then press ENTER. The Model 2410 will display the next and last calibration dates and the calibration count as in the following example:

```
NEXT CAL: 12/15/97  
Last calibration: 12/15/96 Count: 0001
```

Calibration errors

The Model 2410 checks for errors after each calibration step, minimizing the possibility that improper calibration may occur due to operator error.

Front panel error reporting

If an error is detected during comprehensive calibration, the instrument will display an appropriate error message (see Appendix B). The unit will then prompt you to repeat the calibration step that caused the error.

Remote error reporting

You can detect errors while in remote by testing the state of EAV (Error Available) bit (bit 2) in the status byte. (Use the *STB? query to request the status byte.) Query the instrument for the type of error by using the appropriate :SYST:ERR? query. The Model 2410 will respond with the error number and a text message describing the nature of the error. See Appendix B for details.

Front panel calibration

The front panel calibration procedure described below calibrates all ranges of both the current and voltage source and measure functions. Note that each range is separately calibrated by repeating the entire procedure for each range.

Step 1: Prepare the Model 2410 for calibration

1. Turn on the Model 2410 and the digital multimeter, and allow them to warm up for at least one hour before performing calibration.
2. Press the MENU key, and then choose CAL and press ENTER. Select UNLOCK, and then press ENTER. The instrument will display the following:
PASSWORD:
Use ◀, ▶, ▲, ▼, ENTER, or EXIT.
3. Use the up and down range keys to select the letter or number, and use the left and right arrow keys to choose the position. Enter the present password on the display. (Front panel default: 002410.) Press ENTER to complete the process.
4. Press EXIT to return to normal display. Instrument operating states will be set as summarized in Table 2-2.

Step 2: Voltage calibration

Perform the steps below for each voltage range, using Table 2-3 as a guide.

1. Connect the Model 2410 to the digital multimeter, as shown in Figure 2-1. Select the multimeter DC volts measurement function.

NOTE *The 2-wire connections shown assume that remote sensing is not used. Remote sensing may be used, if desired, but it is not essential when using the recommended digital multimeter.*

2. From normal display, press the SOURCE V key.
3. Press the EDIT key to select the source field (cursor flashing in source display field), and then use the down RANGE key to select the 200mV source range.
4. From normal display, press MENU.
5. Select CAL, and then press ENTER. The unit will display the following:

```
CALIBRATION
UNLOCK EXECUTE VIEW-DATES ▶
◀ SAVE LOCK CHANGE-PASSWORD
```

6. Select EXECUTE, and then press ENTER. The instrument will display the following message:

```
V-CAL
Press ENTER to Output +200.00mV
```

7. Press ENTER. The Model 2410 will source +200mV and simultaneously display the following:

```
DMM RDG: +200.0000mV
Use ◀, ▶, ▲, ▼, ENTER, or EXIT.
```

8. Note and record the DMM reading, and then adjust the Model 2410 display to agree exactly with the actual DMM reading. Use the up and down arrow keys to select the digit value, and use the left and right arrow keys to choose the digit position (or use the number keys, 0-9, +/-). Note that the display adjustment range is within $\pm 10\%$ of the present range.
9. After adjusting the display to agree with the DMM reading, press ENTER. The instrument will then display the following:
V-CAL
Press ENTER to Output +000.00mV
10. Press ENTER. The Model 2410 will source 0mV and at the same time display the following:
DMM RDG: +000.0000mV
Use ◀, ▶, ▲, ▼, ENTER, or EXIT.
11. Note and record the DMM reading, and then adjust the Model 2410 display to agree with the actual DMM reading. Note that the display value adjustment limits are within $\pm 1\%$ of the present range.
12. After adjusting the display value to agree with the DMM reading, press ENTER. The unit will then display the following:
V-CAL
Press ENTER to Output -200.00mV
13. Press ENTER. The Model 2410 will source -200mV and display the following:
DMM RDG: -200.0000mV
Use ◀, ▶, ▲, ▼, ENTER, or EXIT.
14. Note and record the DMM reading, and then adjust the Model 2410 display to agree with the DMM reading. Again, the maximum display adjustment is within $\pm 10\%$ of the present range.
15. After adjusting the display value to agree with the DMM reading, press ENTER and note that the instrument displays:
V-CAL
Press ENTER to Output -000.00mV
16. Press ENTER. The Model 2410 will source -0mV and simultaneously display the following:
DMM RDG: +000.0000mV
Use ◀, ▶, ▲, ▼, ENTER, or EXIT.
17. Note and record the DMM reading, and then adjust the display to agree with the DMM reading. Once again, the maximum adjustment is within $\pm 1\%$ of the present range.
18. After adjusting the display to agree with the DMM reading, press ENTER to complete calibration of the present range.
19. Press EXIT to return to normal display, and then select the 2V source range. Repeat steps 2 through 18 for the 2V range.
20. After calibrating the 2V range, repeat the entire procedure for the 20V and 1000V ranges using Table 2-3 as a guide. Be sure to select the appropriate source range with the EDIT and RANGE keys before calibrating each range.
21. Press EXIT as necessary to return to normal display.

Figure 2-1
Voltage
calibration
test connections

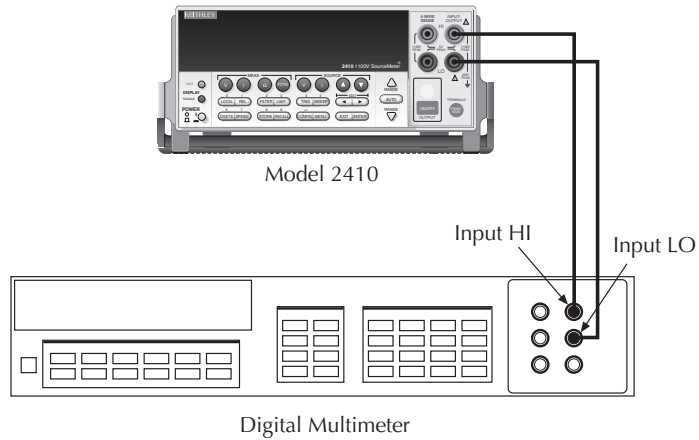

Table 2-3
Front panel voltage calibration

Source range*	Source voltage	Multimeter voltage reading**
0.2V	+200.00mV	_____ mV
	+000.00mV	_____ mV
	-200.00mV	_____ mV
	-000.00mV	_____ mV
2V	+2.0000V	_____ V
	+0.0000V	_____ V
	-2.0000V	_____ V
	-0.0000V	_____ V
20V	+20.000V	_____ V
	+00.000V	_____ V
	-20.000V	_____ V
	-00.000V	_____ V
1000V	+975.00V	_____ V
	+000.00V	_____ V
	-975.00V	_____ V
	-000.00V	_____ V

*Use EDIT and RANGE keys to select source range.

**Multimeter reading used in corresponding calibration step. See procedure.

Step 3: Current calibration

Perform the following steps for each current range using Table 2-4 as a guide.

1. Connect the Model 2410 to the digital multimeter, as shown in Figure 2-2. Select the multimeter DC current measurement function.
2. From normal display, press the SOURCE I key.
3. Press the EDIT key to select the source display field, and then use the down RANGE key to select the 1 μ A source range.
4. From normal display, press MENU.
5. Select CAL, and then press ENTER. The unit will display the following:

```
CALIBRATION
UNLOCK EXECUTE VIEW-DATES ►
◀ SAVE LOCK CHANGE-PASSWORD
```

6. Select EXECUTE, and then press ENTER. The instrument will display the following message:

```
I-CAL
Press ENTER to Output +1.0000 $\mu$ A
```

7. Press ENTER. The Model 2410 will source +1 μ A and simultaneously display the following:

```
DMM RDG: +1.000000 $\mu$ A
Use ◀, ▶, ▲, ▼, ENTER, or EXIT.
```

8. Note and record the DMM reading, and then adjust the Model 2410 display to agree exactly with the actual DMM reading. Use the up and down arrow keys to select the digit value, and use the left and right arrow keys to choose the digit position (or use the number keys, 0-9, +/-). Note that the display adjustment range is within $\pm 10\%$ of the present range.
9. After adjusting the display to agree with the DMM reading, press ENTER. The instrument will then display the following:

```
I-CAL
Press ENTER to Output +0.0000 $\mu$ A
```

10. Press ENTER. The Model 2410 will source 0 μ A and at the same time display the following:

```
DMM RDG: +0.000000 $\mu$ A
Use ◀, ▶, ▲, ▼, ENTER, or EXIT.
```

11. Note and record the DMM reading, and then adjust the Model 2410 display to agree with the actual DMM reading. Note that the display value adjustment limits are within $\pm 1\%$ of the present range.
12. After adjusting the display value to agree with the DMM reading, press ENTER. The unit will then display the following:

```
I-CAL
Press ENTER to Output -1.0000 $\mu$ A
```

13. Press ENTER. The Model 2410 will source -1 μ A and display the following:

```
DMM RDG: -1.000000 $\mu$ A
Use ◀, ▶, ▲, ▼, ENTER, or EXIT.
```

14. Note and record the DMM reading, and then adjust the Model 2410 display to agree with the DMM reading. Again, the maximum display adjustment is within $\pm 10\%$ of the present range.
15. After adjusting the display value to agree with the DMM reading, press ENTER and note that the instrument displays:
I-CAL
Press ENTER to Output $-0.0000\mu\text{A}$
16. Press ENTER. The Model 2410 will source $-0\mu\text{A}$ and simultaneously display the following:
DMM RDG: $+0.000000\mu\text{A}$
Use ◀, ▶, ▲, ▼, ENTER, or EXIT.
17. Note and record the DMM reading, and then adjust the display to agree with the DMM reading. Once again, the maximum adjustment is within $\pm 1\%$ of the present range.
18. After adjusting the display to agree with the DMM reading, press ENTER to complete calibration of the present range.
19. Press EXIT to return to normal display, and then select the $10\mu\text{A}$ source range using the EDIT and up RANGE keys. Repeat steps 2 through 18 for the $10\mu\text{A}$ range.
20. After calibrating the $10\mu\text{A}$ range, repeat the entire procedure for the $100\mu\text{A}$ through 1A ranges using Table 2-4 as a guide. Be sure to select the appropriate source range with the EDIT and up RANGE keys before calibrating each range.

Figure 2-2
Current
calibration
test connections

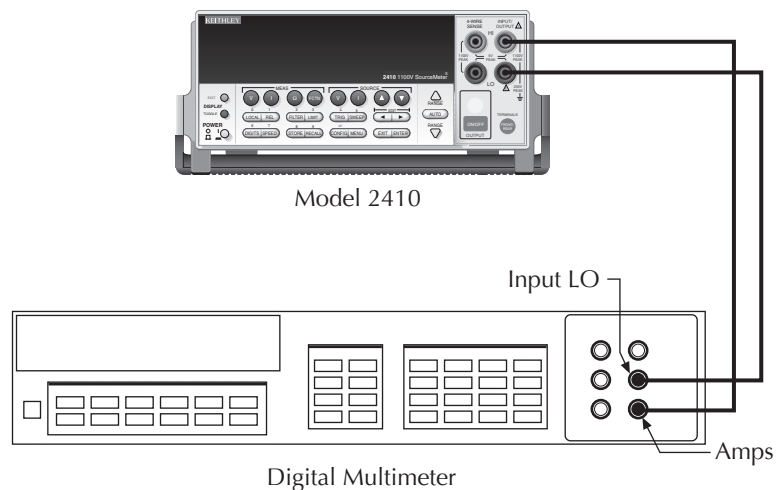

Table 2-4
Front panel current calibration

Source range*	Source current	Multimeter current reading**
1μA	+1.0000μA	_____ μA
	+0.0000μA	_____ μA
	-1.0000μA	_____ μA
	-0.0000μA	_____ μA
10μA	+10.000μA	_____ μA
	+00.000μA	_____ μA
	-10.000μA	_____ μA
	-00.000μA	_____ μA
100μA	+100.00μA	_____ μA
	+000.00μA	_____ μA
	-100.00μA	_____ μA
	-000.00μA	_____ μA
1mA	+1.0000mA	_____ mA
	+0.0000mA	_____ mA
	-1.0000mA	_____ mA
	-0.0000mA	_____ mA
20mA	+20.000mA	_____ mA
	+00.000mA	_____ mA
	-20.000mA	_____ mA
	-00.000mA	_____ mA
100mA	+100.00mA	_____ mA
	+000.00mA	_____ mA
	-100.00mA	_____ mA
	-000.00mA	_____ mA
1A	+1.0000A	_____ A
	+0.0000A	_____ A
	-1.0000A	_____ A
	-0.0000A	_____ A

*Use EDIT and RANGE keys to select source range.

**Multimeter reading used in corresponding calibration step. See procedure.

Step 4: Enter calibration dates and save calibration

NOTE For temporary calibration without saving new calibration constants, proceed to Step 5: Lock out calibration.

1. From normal display, press MENU.
2. Select CAL, and then press ENTER. The Model 2410 will display the following:
CALIBRATION
UNLOCK EXECUTE VIEW-DATES ►
◀ SAVE LOCK CHANGE-PASSWORD
3. Select SAVE, and then press ENTER. The instrument will display the following message:
SAVE CAL
Press ENTER to continue; EXIT to abort calibration sequence.
4. Press ENTER. The unit will prompt you for the calibration date:
CAL DATE: 4/15/96
Use ◀, ▶, ▲, ▼, ENTER, or EXIT.
5. Change the displayed date to today's date, and then press the ENTER key. Press ENTER again to confirm the date.
6. The unit will then prompt for the calibration due date:
NEXT CAL: 4/15/97
Use ◀, ▶, ▲, ▼, ENTER, or EXIT.
7. Set the calibration due date to the desired value, and then press ENTER. Press ENTER again to confirm the date.
8. Once the calibration dates are entered, calibration is complete and the following message will be displayed:
CALIBRATION COMPLETE
Press ENTER to confirm; EXIT to abort
9. Press ENTER to save the calibration data (or press EXIT to abort without saving calibration data). The following message will be displayed:
CALIBRATION SUCCESS
Press ENTER or EXIT to continue.
10. Press ENTER or EXIT to complete process.

Step 5: Lock out calibration

1. From normal display, press MENU.
2. Select CAL, and then press ENTER. The Model 2410 will display the following:
CALIBRATION
UNLOCK EXECUTE VIEW-DATES ►
◀ SAVE LOCK CHANGE-PASSWORD
3. Select LOCK, and then press ENTER. The instrument will display the following message:
CALIBRATION LOCKED.
Press ENTER or EXIT to continue.
4. Press ENTER or EXIT to return to normal display.

Remote calibration

Use the following procedure to perform remote calibration by sending SCPI commands over the IEEE-488 bus or RS-232 port. The remote commands and appropriate parameters are separately summarized for each step.

Remote calibration commands

Table 2-5 summarizes remote calibration commands. For a more complete description of these commands, refer to Appendix B.

Table 2-5
Remote calibration command summary

Command	Description
:CALibration	Calibration subsystem.
:PROTeCted	Cal commands protected by password.
:CODE '<password>'	Unlock cal; changes password if cal is already unlocked. (Default password: KI002410.)
:COUNT?	Query number of times 2410 has been calibrated.
:SAVE	Save calibration data to EEPROM.*
:LOCK	Lock calibration, inhibit SAVE command operation.
:LOCK?	Request cal lock status.
:DATE <y>,<m>,<d>	Program calibration year, month, day.
:DATE?	Query calibration year, month, day.
:NDUE <y>,<m>,<d>	Program calibration due year, month, day.
:NDUE?	Query calibration due year, month, day.
:SENSe <nrf>	Calibrate active measure range. (See Table 2-6 parameters.)
:DATA?	Query measurement cal constants for active range.
:SOURce <nrf>	Calibrate active source range. (See Table 2-7 parameters.)
:DATA?	Query source cal constants for active range.

*Calibration data will not be saved if:

1. Calibration was not unlocked with :CODE command.
 2. Invalid data exists. (For example, cal step failed or was aborted.)
 3. Incomplete number of cal steps were performed. (For example, omitting a negative full-scale step.)
- Ranges that successfully calibrated will be saved if calibration is unlocked. Ranges that failed will not be saved.

Recommended calibration parameters

The maximum calibration command parameter ranges are: 75% to 150% of full scale for positive and negative full scale calibration points; \pm zero calibration steps have $\pm 50\%$ of full scale for valid entry ranges. However, for optimum calibration, use calibration points within the ranges listed in Table 2-6 and Table 2-7. Note that each sense range requires three parameters: zero, negative full scale, and positive full scale. Similarly, each source range requires four parameters: two zero parameters, a positive full-scale parameter, and a negative full-scale parameter.

Table 2-6

Recommended :CALibration:PROTected:SENSe parameter ranges

Sense range	First parameter (zero)	Second parameter (negative full scale)	Third parameter (positive full scale)
0.2V	-0.002 to +0.002	-0.18 to -0.22	+0.18 to +0.22
2V	-0.02 to +0.02	-1.8 to -2.2	+1.8 to +2.2
20V	-0.2 to +0.2	-18 to -22	+18 to +22
1000V	-2 to +2	-800 to -1100	+800 to +1100
1 μ A	-1E-8 to +1E-8	-0.9E-6 to -1.1E-6	+0.9E-6 to +1.1E-6
10 μ A	-1E-7 to +1E-7	-9E-6 to -11E-6	+9E-6 to +11E-6
100 μ A	-1E-6 to +1E-6	-90E-6 to -110E-6	+90E-6 to +110E-6
1mA	-1E-5 to +1E-5	-0.9E-3 to -1.1E-3	+0.9E-3 to +1.1E-3
20mA	-1E-4 to +1E-4	-18E-3 to -22E-3	+18E-3 to +22E-3
100mA	-1E-3 to +1E-3	-90E-3 to -110E-3	+90E-3 to +110E-3
1A	-1E-2 to +1E-2	-0.9 to -1.1	+0.9 to +1.1

Note: Parameter steps for each range may be performed in any order, but all three parameter steps for each range must be completed. For optimum calibration, use parameters within recommended limits.

Table 2-7*Recommended :CALibration:PROTECTED:SOURce parameter ranges*

Source range	First parameter (negative full scale)	Second parameter (negative zero)	Third parameter (positive full scale)	Fourth parameter (positive zero)
0.2V	-0.18 to -0.22	-0.002 to +0.002	+0.18 to +0.22	-0.002 to +0.002
2V	-1.8 to -2.2	-0.02 to +0.02	+1.8 to +2.2	-0.02 to +0.02
20V	-18 to -22	-0.2 to +0.2	+18 to +22	-0.2 to +0.2
1000V	-800 to -1200	-2 to +2	+800 to +1200	-2 to +2
1 μ A	-0.9E-6 to -1.1E-6	-1E-8 to +1E-8	+0.9E-6 to +1.1E-6	-1E-8 to +1E-8
10 μ A	-9E-6 to -11E-6	-1E-7 to +1E-7	+9E-6 to +11E-6	-1E-7 to +1E-7
100 μ A	-90E-6 to -110E-6	-1E-6 to +1E-6	+90E-6 to +110E-6	-1E-6 to +1E-6
1mA	-0.9E-3 to -1.1E-3	-1E-5 to +1E-5	+0.9E-3 to +1.1E-3	-1E-5 to +1E-5
20mA	-18E-3 to -22E-3	-1E-4 to +1E-4	+18E-3 to +22E-3	-1E-4 to +1E-4
100mA	-90E-3 to -110E-3	-1E-3 to +1E-3	+90E-3 to +110E-3	-1E-3 to +1E-3
1A	-0.9 to -1.1	-1E-2 to +1E-2	+0.9 to +1.1	-1E-2 to +1E-2

Note: Parameter steps for each range may be performed in any order, but all four parameter steps for each range must be completed. For optimum calibration, use parameters within recommended limits.

Remote calibration procedure

Step 1: Prepare the Model 2410 for calibration

1. Connect the Model 2410 to the controller IEEE-488 interface or RS-232 port using a shielded interface cable.
2. Turn on the Model 2410 and the test equipment, and allow them to warm up for at least one hour before performing calibration.
3. If you are using the IEEE-488 interface, make sure the primary address of the Model 2410 is the same as the address specified in the program you will be using to send commands. (Use the MENU key and the COMMUNICATION menu to access the IEEE-488 address.)

Step 2: Voltage calibration

1. Connect the Model 2410 to the digital multimeter (see Figure 2-1), and select the multimeter DC volts function.
2. Send the commands summarized in Table 2-8 in the order listed to initialize voltage calibration. (When the :CAL:PROT:CODE command is sent, the instrument will assume the operating states listed in Table 2-2.)
3. Perform the range calibration steps listed in Table 2-9 for each range. For each range:
 - Send the :SOUR:VOLT:RANG command to select the source and sense range being calibrated.. For example, for the 2V range, send the following command:
:SOUR:VOLT:RANG 2
 - Program the source to output the negative full-range value using the :SOUR:VOLT command. For example:
:SOUR:VOLT -2

NOTE Set the source to -975 for the 1000V range.

- Note and record the multimeter reading.
- Use the multimeter reading as the parameter for the :CAL:PROT:SOUR and :CAL:PROT:SENS commands. For example, a typical value for the 2V range would be:
:CAL:PROT:SOUR -1.998
:CAL:PROT:SENS -1.998
- Program the voltage source for 0V output using the :SOUR:VOLT 0.0 command.
- Note the multimeter reading.
- Send the source and sense calibration commands using the multimeter reading for the parameter. For example:
:CAL:PROT:SOUR 1E-3
:CAL:PROT:SENS 1E-3
- Set the source to the positive full-range value using the :SOUR:VOLT command. For example:
:SOUR:VOLT 2

NOTE Set the source to 975 for the 1000V range.

- Note and record the multimeter reading.
- Send the source and sense commands using the multimeter reading as the parameter. For example:
:CAL:PROT:SOUR 1.997
:CAL:PROT:SENS 1.997
- Send the SOUR:VOLT 0.0 command to set the source voltage to 0V.
- Note and record the multimeter reading.
- Send the :CAL:PROT:SOUR command using the multimeter reading as the command parameter. For example:
:CAL:PROT:SOUR -1.02E-3

Table 2-8
Voltage calibration initialization commands

Command	Description
*RST	Restore GPIB defaults.
:SOUR:FUNC VOLT	Activate voltage source.
:SENS:CURR:PROT 0.01	Current limit when voltage source is active.
:SENS:CURR:RANG 0.01	Make sure 100mA range is not active.
:SOUR:VOLT:PROT MAX	Maximum allowable source voltage.
:SYST:RSEN OFF	Disable remote sensing.*
:CAL:PROT:CODE 'KI002410'	Unlock cal.
:OUTP:STAT ON	Turn source on.

*Remote sensing may be used if desired but is not essential when using recommended digital multimeter. To use remote sensing, send :SYST:RSEN ON.

Table 2-9
Voltage range calibration commands

Step	Command/procedure*	Description
1	:SOUR:VOLT:RANGE <Range>	Select source range.
2	:SOUR:VOLT -<Source_value>	Establish negative full-range polarity.
3	Take DMM reading.	Read actual output value.
4	:CAL:PROT:SOUR	Calibrate sense function negative full scale.
5	<DMM_Reading>	
6	Check 2410 for errors.	Calibrate source function negative full
7	:CAL:PROT:SENS <DMM_Reading>	scale.
8	Check 2410 for errors.	
9	:SOUR:VOLT 0.0	Set output to 0V.
10	Take DMM reading.	Read actual output value.
11	:CAL:PROT:SOUR	Calibrate sense function negative zero.
12	<DMM_Reading>	
13	Check 2410 for errors.	Calibration source function negative zero.
14	CAL:PROT:SENS <DMM_Reading>	
15	Check 2410 for errors.	Establish positive full-range polarity.
16	:SOUR:VOLT +<Source_value>	Read actual output value.
17	Take DMM reading.	Calibrate sense function positive full scale.
18	:CAL:PROT:SOUR	
19	<DMM_Reading>	Calibrate source function positive full scale.
20	Check 2410 for errors.	
21	:CAL:PROT:SENS <DMM_Reading>	Set output to 0V.
22	Check 2410 for errors.	Read actual output value.
	:SOUR:VOLT 0.0	Calibrate source positive zero.
	Take DMM reading.	
	:CAL:PROT:SOUR	
	<DMM_Reading>	

*1. Perform complete procedure for each range, where <Range> = 0.2, 2, 20, and 1000, and <Source_value> = 0.2, 2, 20, and 975.

2. <DMM_Reading> parameter is the multimeter reading from previous step.

3. Use :SYST:ERR? query to check for errors.

Step 3: Current calibration

1. Connect the Model 2410 to the digital multimeter (see Figure 2-2), and select the multimeter DC current function.
2. Send the commands summarized in Table 2-10 in the order listed to initialize current calibration.
3. Calibrate each current range using the procedure summarized in Table 2-11. For each range:
 - Send the `:SOUR:CURR:RANG` command to select the source and sense range being calibrated. For example, for the 1mA range, the command is:
`:SOUR:CURR:RANG 1E-3`
 - Program the source to output the negative full-range value using the `:SOUR:CURR` command. For example:
`:SOUR:CURR -1E-3`
 - Note and record the multimeter reading.
 - Use the multimeter reading as the parameter for the `:CAL:PROT:SOUR` and `:CAL:PROT:SENS` commands. For example, a typical value for the 1mA range would be:
`:CAL:PROT:SOUR -1.025E-3`
`:CAL:PROT:SENS -1.025E-3`
 - Program the current source for 0A output using the `:SOUR:CURR 0.0` command.
 - Note the multimeter reading.
 - Send the source and sense calibration commands using the multimeter reading for the parameter. For example:
`:CAL:PROT:SOUR 1E-6`
`:CAL:PROT:SENS 1E-6`
 - Set the source to the positive full-range value using the `:SOUR:CURR` command. For example, for the 1mA range:
`:SOUR:CURR 1E-3`
 - Note and record the multimeter reading.
 - Send the source and sense commands using the multimeter reading as the parameter. For example:
`:CAL:PROT:SOUR 1.03E-3`
`:CAL:PROT:SENS 1.03E-3`
 - Send the `:SOUR:CURR 0.0` command to set the source current to 0A.
 - Note and record the multimeter reading.
 - Send the `:CAL:PROT:SOUR` command using the multimeter reading as the command parameter. For example:
`:CAL:PROT:SOUR -1E-6`

Table 2-10*Current calibration initialization commands*

Command	Description
:SOUR:FUNC CURR	Select source current mode.
:SENS:VOLT:PROT 20	Voltage limit when current source is active.
:SENS:VOLT:RANG 20	Make sure 1000V range is not active.
:OUTP:STAT ON	Turn source on.

Table 2-11*Current range calibration commands*

Step	Command/procedure*	Description
1	:SOUR:CURR:RANGE <Range>	Select source range.
2	:SOUR:CURR -<Source_value>	Establish negative full-range polarity.
3	Take DMM reading.	Read actual output value.
4	:CAL:PROT:SOUR <DMM_Reading>	Calibrate sense function negative full scale.
5	Check 2410 for errors.	
6	:CAL:PROT:SENS <DMM_Reading>	Calibrate source function negative full scale.
7	Check 2410 for errors.	
8	:SOUR:CURR 0.0	Set output to 0A.
9	Take DMM reading.	Read actual output value.
10	:CAL:PROT:SOUR <DMM_Reading>	Calibrate sense function negative zero.
11	Check 2410 for errors.	
12	:CAL:PROT:SENS <DMM_Reading>	Calibration source function negative zero.
13	Check 2410 for errors.	
14	:SOUR:CURR +<Source_value>	Establish positive full-range polarity.
15	Take DMM reading.	Read actual output value.
16	:CAL:PROT:SOUR <DMM_Reading>	Calibrate sense function positive full scale.
17	Check 2410 for errors.	
18	:CAL:PROT:SENS <DMM_Reading>	Calibrate source function positive full scale.
19	Check 2410 for errors.	
20	:SOUR:CURR 0.0	Set output to 0A.
21	Take DMM reading.	Read actual output value.
22	:CAL:PROT:SOUR <DMM_Reading>	Calibrate source positive zero.

*1. Perform complete procedure for each range, where <Range> and <Source_value> = 1E-6, 10E-6, 100E-6, 1E-3, 20E-3, 100E-3, or 1.

2. <DMM_Reading> parameter is the multimeter reading from the previous step.

3. Use :SYST:ERR? query to check for errors.

Step 4: Program calibration dates

Use following commands to set the calibration date and calibration due date:

:CAL:PROT:DATE <year>, <month>, <day> (Calibration date)

:CAL:PROT:NDUE <year>, <month>, <day> (Next calibration due date)

Note that the year, month, and day must be separated by commas. The allowable range for the year is from 1996 to 2095, the month is from 1 to 12, and the day is from 1 to 31.

Step 5: Save calibration constants

Calibration is now complete, so you can store the calibration constants in EEROM by sending the following command:

:CAL:PROT:SAVE

NOTE *Calibration will be temporary unless you send the SAVE command. Also, calibration data will not be saved if (1) calibration is locked, (2) invalid data exists, or (3) all steps were not completed.*

Step 6: Lock out calibration

To lock out further calibration, send the following command after completing the calibration procedure:

:CAL:PROT:LOCK

Single-range calibration

Normally, the complete calibration procedure should be performed to ensure that the entire instrument is properly calibrated. In some instances, however, you may want to calibrate only certain ranges. To do so, complete the entire procedure only for the ranges to be calibrated. Keep in mind, however, that you must complete all parameter steps for each source or sense range. Also be sure to set calibration dates and save calibration after calibrating the desired ranges.

3 Routine Maintenance

Introduction

The information in this section deals with routine type maintenance that can be performed by the operator.

Line fuse replacement

WARNING **Disconnect the line cord at the rear panel, and remove all test leads connected to the instrument (front and rear) before replacing the line fuse.**

The power line fuse is accessible from the rear panel, just above the AC power receptacle (see Figure 3-1).

Perform the following steps to replace the line fuse:

1. Carefully grasp and squeeze together the locking tabs that secure the fuse carrier to the fuse holder.
2. Pull out the fuse carrier, and replace the fuse with the type specified in Table 3-1.

CAUTION **To prevent instrument damage, use only the fuse type specified in Table 3-1.**

3. Re-install the fuse carrier.

NOTE *If the power line fuse continues to blow, a circuit malfunction exists and must be corrected. Refer to the troubleshooting section of this manual for additional information.*

Table 3-1
Power line fuse

Line voltage	Rating	Keithley part no.
100-240V	250V, 2.5A, slow blow 5 × 20mm	FU-106-2.5

Figure 3-1
Rear panel

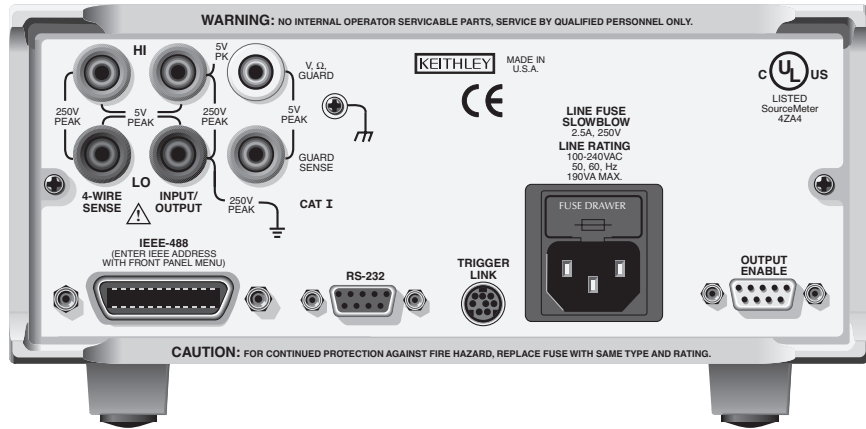

Troubleshooting **4**

Introduction

This section of the manual will assist you in troubleshooting and repairing the Model 2410. Included are self-tests, test procedures, troubleshooting tables, and circuit descriptions. Note that disassembly instructions are located in Section 5, and component layout drawings are found at the end of Section 6.

WARNING **The information in this section is intended for qualified service personnel only. Do not perform these procedures unless you are qualified to do so. Some of these procedures may expose you to hazardous voltages that could cause personal injury or death. Use caution when working with hazardous voltages.**

Repair considerations

Before making any repairs to the Model 2410, be sure to read the following considerations.

CAUTION **The PC boards are built using surface mount techniques and require specialized equipment and skills for repair. If you are not equipped and/or qualified, it is strongly recommended that you send the unit back to the factory for repairs or limit repairs to the PC board replacement level. Without proper equipment and training, you could damage a PC board beyond repair.**

- Repairs will require various degrees of disassembly. However, it is recommended that the Front Panel Tests be performed prior to any disassembly. The disassembly instructions for the Model 2410 are contained in Section 5 of this manual.
- Do not make repairs to surface mount PC boards unless equipped and qualified to do so (see previous CAUTION).
- When working inside the unit and replacing parts, be sure to adhere to the handling pre-cautions and cleaning procedures explained in Section 5.
- Many CMOS devices are installed in the Model 2410. These static-sensitive devices require special handling as explained in Section 5.
- When a circuit board is removed or a component is replaced, the Model 2410 must be recalibrated. See Section 2 for details on calibrating the unit.

Power-on self-test

During the power-on sequence, the Model 2410 will perform a checksum test on its EPROM and test its RAM. If one of these tests fail, the instrument will lock up.

Front panel tests

There are three front panel tests: one to test the functionality of the front panel keys and two to test the display. In the event of a test failure, refer to Display board checks for details on troubleshooting the display board.

KEYS test

The KEYS test lets you check the functionality of each front panel key. Perform the following steps to run the KEYS test.

1. Display the MAIN MENU by pressing the MENU key.
2. Select TEST, and press ENTER to display the SELF-TEST MENU.
3. Select DISPLAY-TESTS, and press ENTER to display the following menu:
FRONT PANEL TESTS
KEYS DISPLAY-PATTERNS CHAR-SET
4. Select KEYS, and press ENTER to start the test. When a key is pressed, the label name for that key will be displayed to indicate that it is functioning properly. When the key is released, the “No keys pressed” message is displayed.
5. Pressing EXIT tests the EXIT key. However, the second consecutive press of EXIT aborts the test and returns the instrument to the FRONT PANEL TESTS MENU. Continue pressing EXIT to back out of the menu structure.

DISPLAY PATTERNS test

The display patterns test lets you verify that each pixel and annunciator in the vacuum fluorescent display is working properly. Perform the following steps to run the display patterns test:

1. Display the MAIN MENU by pressing the MENU key.
2. Select TEST, and press ENTER to display the SELF-TEST MENU.
3. Select DISPLAY-TESTS, and press ENTER to display the following menu:
FRONT PANEL TESTS
KEYS DISPLAY-PATTERNS CHAR-SET
4. Select DISPLAY-PATTERNS, and press ENTER to start the display test. There are five parts to the display test. Each time a front panel key (except EXIT) is pressed, the next part of the test sequence is selected. The five parts of the test sequence are:
 - Checkerboard pattern (alternate pixels on) and all annunciators.
 - Checkerboard pattern and the annunciators that are on during normal operation.
 - Horizontal lines (pixels) of the first digit are sequenced.
 - Vertical lines (pixels) of the first digit are sequenced.
 - Each digit (and adjacent annunciator) is sequenced. All the pixels of the selected digit are on.
5. When finished, abort the display test by pressing EXIT. The instrument returns to the FRONT PANEL TESTS MENU. Continue pressing EXIT to back out of the menu structure.

CHAR SET test

The character set test lets you display all characters. Perform the following steps to run the character set test:

1. Display the MAIN MENU by pressing the MENU key.
2. Select TEST, and press ENTER to display the SELF-TEST MENU.
3. Select DISPLAY-TESTS, and press ENTER to display the following menu:
FRONT PANEL TESTS
KEYS DISPLAY-PATTERNS CHAR-SET
4. Select CHAR-SET, and press ENTER to start the character set test. Press any key except EXIT to cycle through all displayable characters.
5. When finished, abort the character set test by pressing EXIT. The instrument returns to the FRONT PANEL TESTS MENU. Continue pressing EXIT to back out of the menu structure.

Principles of operation

The following information is provided to support the troubleshooting tests and procedures covered in this section of the manual. Refer to the following drawings:

- Figure 4-1 — Overall block diagram
- Figure 4-2 — Analog circuitry block diagram
- Figure 4-3 — Power supply block diagram
- Figure 4-4 — Output stage simplified schematic
- Figure 4-5 — Digital circuitry block diagram

Overall block diagram

Figure 4-1 shows an overall block diagram of the Model 2410. Circuitry is divided into three general areas:

- **Analog circuits** — includes circuits such as the DACs, clamps, output stage, and feedback circuits, as well as measurement circuits such as the A/D converter.
- **Digital circuits** — includes the microcomputer that controls the analog section, front panel, and the GPIB and RS-232 ports, as well as associated interfacing circuits.
- **Power supplies** — converts the AC line voltage into DC voltages that supply the power for the digital and analog circuits, and the output stage.

Figure 4-1
Overall
block diagram

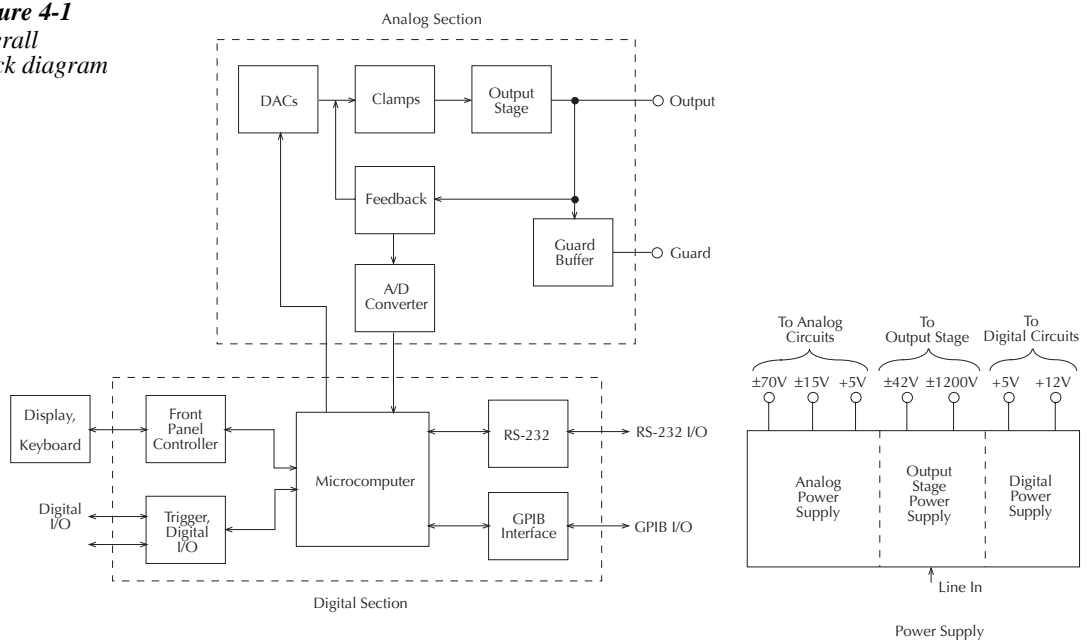

Analog circuits

Figure 4-2 shows the analog circuitry block.

D/A converters control the programmed voltage and current, or voltage compliance and current compliance. Each DAC has two ranges, a 10V full-scale output or a 1V full-scale output. The DAC outputs are fed to the summing node, FB. Either the V DAC or the I DAC has the ability to control the main loop. If the unit is set for SV (source voltage), it will source voltage until the compliance current is reached (as determined by the I DAC setting), and the current loop will override the voltage loop. If, however, the unit is set for SI (source current), it will source current until the compliance voltage is reached (as determined by the V DAC setting), and the voltage loop will override the current loop. A priority bit in the V clamp/I clamp circuit controls these functions.

The error amplifier adds open-loop gain and slew-rate control to the system to assure accuracy and provide a controllable signal for the output stage, which provides the necessary voltage and current gain to drive the output. Sense resistors in the HI output lead provide output current sensing, and a separate sense resistor is used for each current range. The 1A range uses 0.2V full-scale for a full-range 1A output, while all other ranges use 2V output for full-scale current. Voltage feedback is routed either internally or externally.

There are four voltage ranges: 0.2V, 2V, 20V, and 1000V. The feedback gain changes for only the 20V and 1000V ranges, resulting in three unique feedback gain values. A multiplexer directs the voltage feedback, current feedback, reference, or ground signal to the A/D converter. An opto-isolated interface provides control signals for both DACs, analog circuit control, and A/D converter communication to the digital section.

Figure 4-2
*Analog circuitry
 block diagram*

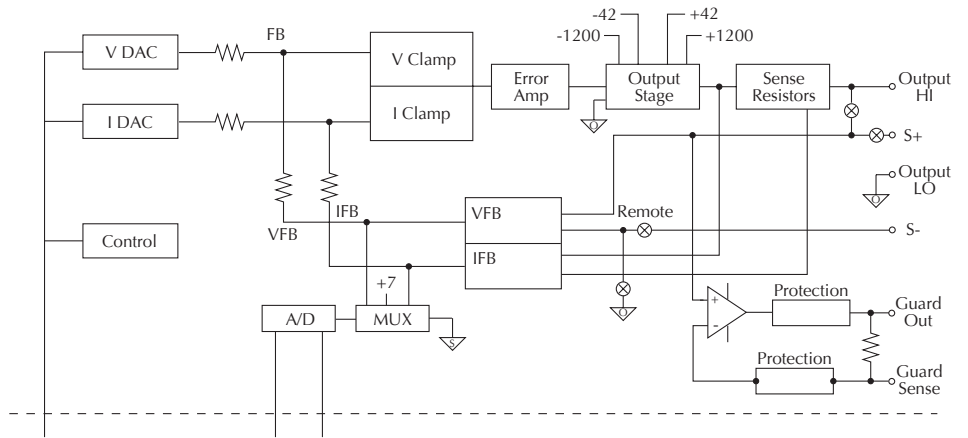

Power supply

Figure 4-3 shows a block diagram of the Model 2410 power delivery system.

The offline flyback switching power supply provides all power for the instrument while providing universal inputs for the 110/120V line. The digital board runs directly from the switcher, including the +12VD supply to program the flash ROM.

A constant-frequency switching supply runs off the +12VD supplies and generates all the floating supply voltages for the analog board: +5V, $\pm 15V$, and $\pm 70V_F$. An AC output (low voltage) supplies the analog board with the power it uses to derive the output stage supply voltages, $\pm 42V$ and $\pm 1200V$.

Figure 4-3
Power supply
block diagram

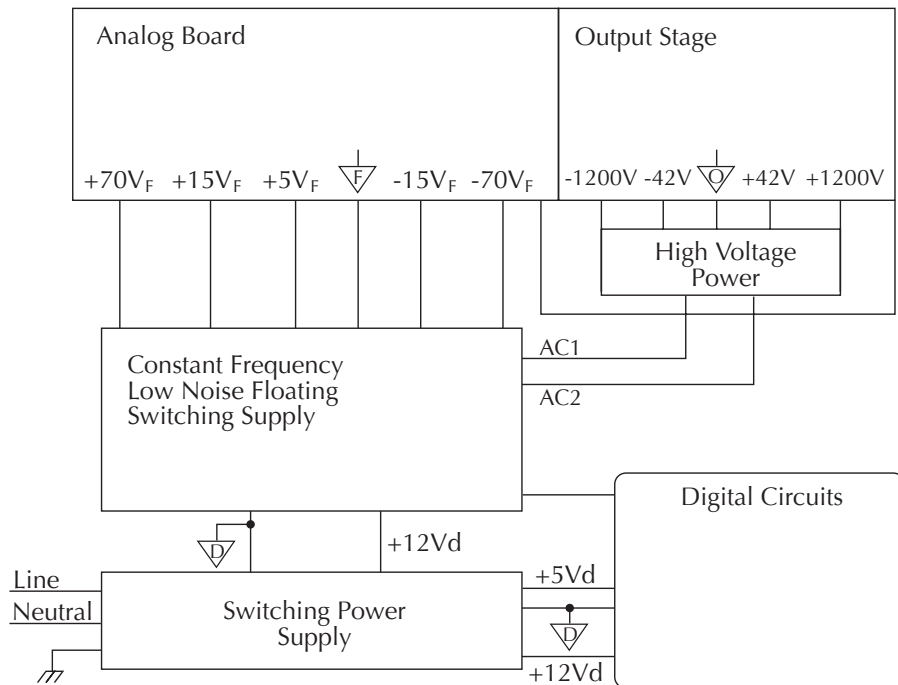

Output stage

Figure 4-4 shows a simplified schematic of the output stage.

The Model 2410 output stage serves two purposes: (1) it converts signals from floating common to output common, and (2) it provides both voltage and current amplification. The output stage drive transistors are biased in class B configuration to prevent the possibility of thermal runaway with high-current output values. High-current taps for the $\pm 20\text{V}$ outputs are provided to reduce power dissipation on the 20V and lower ranges.

Output transistors Q518 and Q521 are cascoded with output MOSFETs Q516 and Q523. All other MOSFETs and transistors are slaves, and the voltages across these devices are determined by the resistor-capacitor ladder circuits shown. Coarse current limits are built into the output stage.

Figure 4-4
Output stage
simplified
schematic

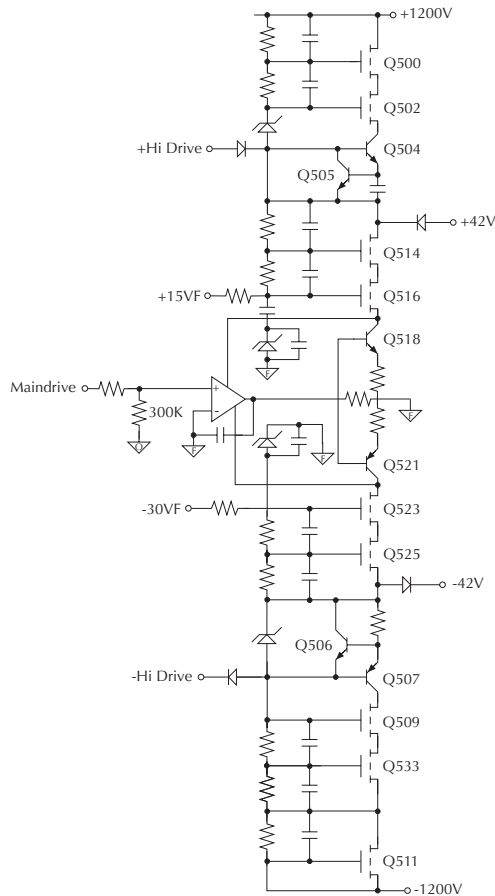

A/D converter

The SourceMeter unit uses a multi-slope charge balance A/D converter with a single-slope charge balance run-down. The converter is controlled by gate array U610. Commands are issued by the MPU on the digital board through communications opto-isolators to U610, and U610 sends A/D reading data back through opto-isolators to the digital board for calibration and processing.

Active guard

The Model 2410 has an active guard or "six-wire ohms" circuit used to measure complex devices. This circuitry provides a low-current (50mA) equivalent of the voltage on output HI. If the unit is in the SV mode, the low-current equivalent of the source voltage will appear on the guard terminal. If the unit is in the SI mode, the voltage on output HI is equal to the source current multiplied by the external resistance value. An equivalent voltage will be generated by the guard circuit, and a guard sense terminal is provided to sense around the voltage drop in the guard leads since significant current can flow (50mA).

Digital circuitry

Refer to Figure 4-5 for the following discussion on digital circuitry.

The core digital circuitry uses a Motorola 68332 microcontroller running at 16.78MHz. The memory configuration includes two 256K X 8-bit EEPROMs and two 128K X 8-bit RAMs used in parallel to utilize the 16-bit data bus of the MPU. The RAM is battery backed-up, providing continued storage of data buffer information during power-down cycles, and flash ROM support allows internal firmware upgrades using either the serial or GPIB port for downloading new firmware. All calibration constants and save setup o are stored in a separate serial EEPROM. Setups 1 through 4 are stored in battery backed up RAM.

External communication is provided via GPIB and serial interfaces. A 9914 GPIA IEEE-488 standard interface IC is used for the GPIB, and a 68332 Queued Serial Module (QSM) provides the serial UART. For internal communications, the Time Processing Unit (TPU) is used for serial communications with the front panel display module, and both the TPU and QSM handle digital-to-analog interfacing.

Figure 4-5
Digital circuitry
block diagram

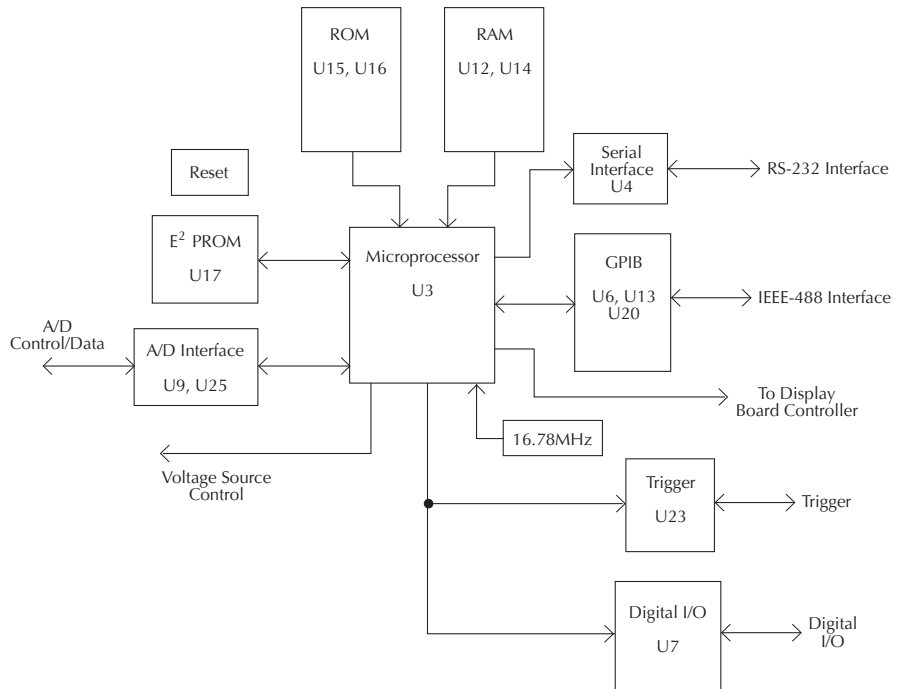

Display board

U902 is the display microcontroller that controls the VFD (vacuum fluorescent display) and interprets key data. The microcontroller has four peripheral I/O ports that are used for the various control and read functions.

Display data is serially transmitted to the microcontroller from the digital board via the TXB line to the microcontroller PD0 terminal. In a similar manner, key data is serially sent back to the digital board through the RXB line via PD1. The 4MHz clock for the microcontroller is generated on the display board.

DS901 is the VFD (vacuum fluorescent display) module, which can display up to 49 characters. Each character is organized as a 5×7 matrix of dots or pixels and includes a long underbar segment to act as a cursor.

The display uses a common multiplexing scheme with each character refreshed in sequence. U903 and U904 are the grid drivers, and U901 and U905 are the dot drivers. Note that dot driver and grid driver data is serially transmitted from the microcontroller (PD3 and PC1).

The VFD requires both +60VDC and 5VAC for the filaments. These VFD voltages are supplied by U625, which is located on the digital board.

The front panel keys (S901-S931) are organized into a row-column matrix to minimize the number of microcontroller peripheral lines required to read the keyboard. A key is read by strobing the columns and reading all rows for each strobed column. Key down data is interpreted by the display microcontroller and sent back to the main microprocessor using proprietary encoding schemes.

Troubleshooting

Troubleshooting information for the various circuits is summarized below. See the component layout drawings at the end of Section 6 for test point locations.

Display board checks

If the front panel display tests indicate that there is a problem on the display board, use Table 4-1. See principles of operation for display circuit theory.

Table 4-1
Display board checks

Step	Item/component	Required condition	Remarks
1	Front panel test	Verify that all segments operate.	Use front panel display test.
2	P1005, pin 5	+5V $\pm 5\%$	Digital +5V supply.
3	P1005, pin 9	+37V $\pm 5\%$	Display +37V supply.
4	U902, pin 1	Goes low briefly on power up, then goes high.	Microcontroller RESET.
5	U902, pin 43	4MHz square wave.	Controller 4MHz clock.
6	U902, pin 32	Pulse train every 1ms.	Control from main processor.
7	U902, pin 33	Brief pulse train when front panel key is pressed.	Key down data sent to main processor.

Power supply checks

Power supply problems can be checked out using Table 4-2. See principles of operation for circuit theory on the power supply.

Table 4-2
Power supply checks

Step	Item/component	Required condition	Remarks
1	Line fuse	Check continuity.	Remove to check.
2	Line power	Plugged into live receptacle, power on.	Check for correct power-up sequence.
3	CR500 cathode	+1200V \pm 10%	Referenced to TP501.
4	CR503 anode	-1200V \pm 10%	Referenced to TP501.
5	CR504 cathode	+42V \pm 10%	Referenced to TP501.
6	CR505 anode	-42V \pm 10%	Referenced to TP501.
7	TP506	+70V \pm 10%	+70VF, referenced to TP500.
8	TP507	+15V \pm 5%	+15VF, referenced to TP500.
9	TP508	-15V \pm 10%	-15VF, referenced to TP500.
10	TP509	-70V \pm 10%	-70VF, referenced to TP500.
11	TP510	+5V \pm 5%	+5VF, referenced to TP500.

Digital circuitry checks

Digital circuit problems can be checked out using Table 4-3. See principles of operation for a digital circuit description.

Table 4-3
Digital circuitry checks

Step	Item/component	Required condition	Remarks
1	Power-on test	RAM OK, ROM OK.	Verify that RAM and ROM are functional.
2	U3, pin 19, TP3	Digital common.	All signals referenced to digital common.
3	U3, pin 7, TP1	+5V	Digital logic supply.
4	U3, pin 68, TP10	Low on power-up, then goes high.	MPU RESET line.
5	U3, lines A0-A19	Check for stuck bits.	MPU address bus.
6	U3, lines D0-D15	Check for stuck bits.	MPU data bus.
7	U3, pin 66, W23	16.78MHz.	MPU clock.
8	U4, pin 7	Pulse train during RS-232 I/O.	RS-232 RX line.
9	U4, pin 8	Pulse train during RS-232 I/O.	RS-232 TX line.
10	U13, pins 34-42	Pulse train during IEEE-488 I/O.	IEEE-488 data bus.
11	U13, pins 26-31	Pulses during IEEE-488 I/O.	IEEE-488 command lines.
12	U13, pin 24	Low with remote enabled.	IEEE-488 REN line.
13	U13, pin 25	Low during interface clear.	IEEE-488 IFC line.
14	U3, pin 43	Pulse train.	D_ADDDATA
15	U3, pin 44	Pulse train.	D_DATA
16	U3, pin 45	Pulse train.	D_CLK
17	U3, pin 47	Pulse train.	D_STB

Analog circuitry checks

Table 4-4 summarizes analog circuitry checks.

Table 4-4
Analog circuitry checks

Step	Item/ component	Required condition	Remarks
1*	TP200	>1100V voltage protection	-13V \pm 1V
2*	TP201	SOURCE +10V	-5V \pm .5V
3*	TP202	SOURCE +10V (SVMI)	-10V \pm 1V
4*	TP203	SOURCE +10V	-10.5V \pm 1V
5*	TP213	SOURCE +10V	0V \pm .1V
6**	TP218	OUTPUT COM	7V \pm .7V
7**	TP219	OUTPUT COM	7V \pm .7V
8**	TP214	SVMI, OUTPUT ON, 20V	20V \pm .5V
9*	TP232	Bench defaults	6.4V \pm .6V

* Measured with respect to FCOM (TP500).

** Measured with respect to OCOM (TP501).

Battery replacement

WARNING **Disconnect the instrument from the power line and all other equipment before changing the battery.**

The volatile memories of the Model 2410 are protected by a replaceable battery when power is off. Typical life for the battery is approximately ten years, but the battery should be replaced if the voltage drops below 2.5V regardless of age. The battery should be suspected if the instrument no longer retains buffer data or user-defined operating parameters, such as instrument set-ups, source memory, and math expressions. If the battery is absent or totally exhausted, the display will show the “Reading buffer data lost” message shortly after the Model 2410 is switched on.

The battery is a 3V wafer-type lithium cell (Panasonic BR-2330-1VC), which is located on the digital board. Replacement of the battery requires removal of the case cover and analog board assembly. (See Section 5.) Use only the recommended battery.

NOTE *Calibration constants and user-defined parameters will be lost when the battery is replaced. The Model 2410 must be re-calibrated (Section 2) after the battery is replaced.*

WARNING **The precautions below must be followed to avoid personal injury.**

1. Wear safety glasses or goggles when working with lithium batteries.
2. Do not short the battery terminals together.
3. Keep lithium batteries away from all liquids.
4. Do not attempt to recharge lithium batteries.
5. Observe proper polarity when installing the battery.
6. Do not incinerate or otherwise expose the battery to excessive heat (>60°C).
7. Bulk quantities of lithium batteries should be disposed of as a hazardous waste.

To replace the battery, carefully unsolder it, and then solder the new one in its place.

Re-assemble the instrument and turn it on. The “Reading buffer data lost” error message will be displayed. Send the :SYST:MEM:INIT command to perform the following:

- Clear the reading buffer.
- Initialize instrument setups 1 to 4 to the present instrument settings.
- Initialize all 100 source memory locations to the present instrument settings.
- Delete user math expressions.

No comm link error

A “No Comm Link” error indicates that the front panel processor has stopped communicating with the main processor, which is located on the digital board. This error indicates that one of the main processor ROMs may require reseating in its socket. ROMs may be reseated as follows:

1. Turn off the power, and disconnect the line cord and all other test leads and cables from the instrument.
2. Remove the case cover as outlined in Section 5.
3. Remove the analog board assembly as outlined in Section 5.
4. Locate the two firmware ROMs, U15 and U16, located on the digital board. These are the only ICs installed in sockets. (Refer to the component layout drawing at the end of Section 6 for exact locations.)
5. Carefully push down on each ROM IC to make sure it is properly seated in its socket.

CAUTION **Be careful not to push down excessively, or you might crack the digital board.**

6. Connect the line cord, and turn on the power. If the problem persists, additional troubleshooting will be required.

5 Disassembly

Introduction

This section explains how to handle, clean, and disassemble the Model 2410. Disassembly drawings are located at the end of this section.

Handling and cleaning

To avoid contaminating PC board traces with body oil or other foreign matter, avoid touching the PC board traces while you are repairing the instrument. Motherboard areas covered by the shield have high-impedance devices or sensitive circuitry where contamination could cause degraded performance.

Handling PC boards

Observe the following precautions when handling PC boards:

- Wear cotton gloves.
- Only handle PC boards by the edges and shields.
- Do not touch any board traces or components not associated with repair.
- Do not touch areas adjacent to electrical contacts.
- Use dry nitrogen gas to clean dust off PC boards.

Solder repairs

Observe the following precautions when you must solder a circuit board:

- Use an OA-based (organic activated) flux, and take care not to spread the flux to other areas of the circuit board.
- Remove the flux from the work area when you have finished the repair by using pure water with clean, foam-tipped swabs or a clean, soft brush.
- Once you have removed the flux, swab only the repair area with methanol, then blow-dry the board with dry nitrogen gas.
- After cleaning, allow the board to dry in a 50°C, low-humidity environment for several hours.

Static sensitive devices

CMOS devices operate at very high impedance levels. Therefore, any static that builds up on you or your clothing may be sufficient to destroy these devices if they are not handled properly. Use the following precautions to avoid damaging them:

CAUTION Many CMOS devices are installed in the Model 2410. Handle all semiconductor devices as being static sensitive.

- Transport and handle ICs only in containers specially designed to prevent static buildup. Typically, you will receive these parts in anti-static containers made of plastic or foam. Keep these devices in their original containers until ready for installation.
- Remove the devices from their protective containers only at a properly grounded work station. Also, ground yourself with a suitable wrist strap.
- Handle the devices only by the body; do not touch the pins.
- Ground any printed circuit board into which a semiconductor device is to be inserted to the bench or table.
- Use only anti-static type desoldering tools.
- Use only grounded-tip solder irons.
- Once the device is installed in the PC board, it is normally adequately protected, and you can handle the boards normally.

Assembly drawings

Use the assembly drawings located at the end of this section to assist you as you disassemble and re-assemble the Model 2410. Also, refer to these drawings for information about the Keithley part numbers of most mechanical parts in the unit.

- Front panel assembly — 2410-040
- Analog board/heat sink/shield assembly — 2410-050
- Chassis assembly — 2410-051
- Chassis/analog board assembly — 2410-052
- Final chassis assembly — 2410-053

Case cover removal

Follow the steps below to remove the case cover to gain access to internal parts.

WARNING Before removing the case cover, disconnect the line cord and any test leads from the instrument.

1. **Remove handle** — The handle serves as an adjustable tiltbail. Adjust its position by gently pulling it away from the sides of the instrument case and swinging it up or down. To remove the handle, swing the handle below the bottom surface of the case and back until the orientation arrows on the handles line up with the orientation arrows on the mounting ears. With the arrows lined up, pull the ends of the handle away from the case.
2. **Remove mounting ears** — Remove the screw that secures each mounting ear. Pull down and out on each mounting ear.

NOTE When re-installing the mounting ears, make sure to mount the right ear to the right side of the chassis and the left ear to the left side of the chassis. Each ear is marked “RIGHT” or “LEFT” on its inside surface.

3. **Remove rear bezel** — To remove the rear bezel, loosen the two screws that secure the rear bezel to the chassis, and then pull the bezel away from the case.
4. **Remove grounding screws** — Remove the two grounding screws that secure the case to the chassis. They are located on the bottom of the case at the back.
5. **Remove chassis** — To remove the case, grasp the front bezel of the instrument, and carefully slide the chassis forward. Slide the chassis out of the metal case.

Analog board removal

Perform the following steps to remove the analog board. This procedure assumes that the case cover is already removed.

1. Disconnect the front and rear input terminals.
You must disconnect these input terminal connections for both the front and rear inputs:
 - INPUT/OUTPUT HI and LO
 - 4-WIRE SENSE HI and LO
 - V, Ω , GUARD, and GUARD SENSE (rear panel only)

Remove all the connections by pulling the wires off the pin connectors, and then remove the ferrite noise filters from the chassis. During reassembly, use the following table to identify input terminals:

Terminal	Front wire color	Rear wire color
INPUT/OUTPUT HI	Red	White/Red
INPUT/OUTPUT LO	Black	White/Black
4-WIRE SENSE HI	Yellow	White/Yellow
4-WIRE SENSE LO	Gray	White/Gray
V, Ω , GUARD	—	White
GUARD SENSE	—	Blue/White

2. Unplug cables.
 - Carefully unplug the ribbon cables at J1001, J1002, and J1003.
 - Unplug the ON/OFF cable at J1034.
3. Remove screws.
 - Remove the two fastening screws that secure the analog board assembly to the chassis. These screws are located on the side of the board opposite from the heat sink.
 - Remove the two screws that secure the heat sink to the chassis.
4. Remove analog board assembly.
 - After all screws have been removed, carefully lift the analog board assembly free of the main chassis.
5. Disassemble analog board assembly.
 - Remove the screws that secure the analog board and heat sink to the analog board subchassis.
 - Carefully remove the heat sink by sliding the clips off the power transistors.

CAUTION Be careful not to damage the heat sink insulation layer.

- Remove the analog board from the subchassis.
- Remove the four screws that secure the bottom cover, and then remove the cover from the bottom of the PC board.

NOTE When re-installing the heat sink, make sure all clips are properly installed and centered on each pair of output transistors.

Digital board removal

Perform the following steps to remove the digital board. This procedure assumes that the analog board assembly is already removed.

1. Remove the IEEE-488, digital I/O, and RS-232 fasteners.
The IEEE-488, digital I/O, and RS-232 connectors each have two nuts that secure the connectors to the rear panel. Remove these nuts.
2. Remove the POWER switch rod.
At the switch, place the edge of a flat-blade screwdriver in the notch on the pushrod. Gently twist the screwdriver while pulling the rod from the shaft.
3. Unplug cables:
 - Unplug the display board ribbon cables.
 - Unplug the cables going to the power supply.
 - Unplug the rear panel power module cable.
4. Remove digital board.
Slide the digital board forward until it is free of the guide pins, then remove the board.
During re-assembly, replace the board, and start the IEEE-488, digital I/O, and RS-232 connector nuts and the mounting screw. Tighten all the fasteners once they are all in place and the board is correctly aligned.

Front panel disassembly

Use the following steps to remove the display board and/or the pushbutton switch pad.

1. Unplug the display board ribbon cable.
2. Remove the front panel assembly.
This assembly has four retaining clips that snap onto the chassis over four pem nut studs. Two retaining clips are located on each side of the front panel. Pull the retaining clips outward and, at the same time, pull the front panel assembly forward until it separates from the chassis.
3. Using a thin-bladed screw driver, pry the plastic PC board stop (located at the bottom of the display board) until the bar separates from the casing. Pull the display board from the front panel.
4. Remove the switch pad by pulling it from the front panel.

Removing power components

The following procedures to remove the power supply and/or power module require that the case cover and motherboard be removed, as previously explained.

Power supply removal

Perform the following steps to remove the power supply:

1. Remove the analog board.
2. Unplug the two cables coming from the digital board.
3. Remove the four screws that secure the power supply to the bottom of the chassis.
4. Remove the power supply from the chassis.

Power module removal

Perform the following steps to remove the rear panel power module:

1. Remove the analog board.
2. Unplug the cable connecting the power module to the digital board.
3. Disconnect the power module's ground wire. This green and yellow wire connects to a threaded stud on the chassis with a kep nut.
4. Squeeze the latches on either side of the power module while pushing the module from the access hole.

WARNING To avoid electrical shock, which could result in injury or death, the ground wire of the power module must be connected to chassis ground. When installing the power module, be sure to re-connect the green and yellow ground wire to the threaded stud on the chassis.

Instrument re-assembly

Re-assemble the instrument by reversing the previous disassembly procedures. Make sure that all parts are properly seated and secured and that all connections are properly made.

WARNING To ensure continued protection against electrical shock, verify that power line ground (green and yellow wire attached to the power module) is connected to the chassis. Also make certain that the two bottom case screws are properly installed to secure and ground the case cover to the chassis.



6 Replaceable Parts

Introduction

This section contains replacement parts information and component layout drawings for the Model 2410.

Parts lists

The electrical parts lists for the Model 2410 are shown in tables at the end of this section. For part numbers to the various mechanical parts and assemblies, use the Miscellaneous parts list and the assembly drawings provided at the end of Section 5.

Ordering information

To place an order or to obtain information concerning replacement parts, contact your Keithley representative or the factory (see inside front cover for addresses). When ordering parts, be sure to include the following information:

- Instrument model number (Model 2410)
- Instrument serial number
- Part description
- Component designation (if applicable)
- Keithley part number

Factory service

If the instrument is to be returned to Keithley Instruments for repair, perform the following:

- Call the Repair Department at 1-800-833-9200 for a Return Material Authorization (RMA) number.
- Complete the service form at the back of this manual, and include it with the instrument.
- Carefully pack the instrument in the original packing carton.
- Write ATTENTION REPAIR DEPARTMENT and the RMA number on the shipping label.

Component layouts

The component layouts for the various circuit boards are provided on the following pages.

- Analog board — 2410-100
- Display board — 2400-110
- Digital board — 2400-140

Table 6-1

Analog board parts list

Circuit designation	Description	Keithley part no.
C200-203, 205-210, 225, 226, 231, 232, 237, 238	CAP, .1UF, 10%, 25V, CERAMIC	C-495-.1
C204, 404, 608 ,609, 550-553	CAP, .01UF, 10%, 50V CERAMIC	C-491-.01
C211-214	CAP, 1000PF,10%, 50V, MONO CERAMIC	C-452-1000P
C215-222, 611	CAP,100PF, 5%, 100V, CERAMIC	C-465-100P
C223, 224, 227-230, 233-236, 239, 240, 320	CAP, 33PF, 5%, 100V, CERAMIC	C-465-33P
C241	CAP,1000PF,1%,50V,CERAMIC	C-347-1000P
C242, 243,248, 249, 252-255, 258-261, 269-271	CAP, .1UF, 10%, 25V, CERAMIC	C-495-.1
C244, 245	CAP, .01UF, 10%, 200V CERAMIC	C-472-.01
C247	CAP, .01, 5%, 50V, NPO	C-514-.01
C250, 290, 291, 297-300, 252-255, 258-261, 269-271	CAP, .1UF, 10%, 25V, CERAMIC	C-495-.1
C256, 257, 340, 341	CAP, 22PF, 10%, 100V, CERAMIC	C-451-22P
C267, 513	CAPACITOR, SMT	C-543-560P
C273-282, 284-289, 305-310, 321, 322, 600-602	CAP, .1UF, 10%, 25V, CERAMIC	C-495-.1
C283, 337	CAP, 100P, 10%, 100V CERAMIC	C-451-100P
C296	CAP,33PF,10%,1000V,CERAMIC	C-64-33P
C301, 302	CAP, 1000PF,10%, 50V, MONO CERAMIC	C-452-1000P
C311	CAP, 100UF, 20%, 10V, ALUM ELEC	C-483-100
C312-319	CAP,10PF,5%,100V,CERAMIC	C-372-10P
C323-326, 603, 604, 615	CAP, 47P, 5%, 100V, CERAMIC	C-465-47P
C329	CAP, 220PF, 10%, 100V, CERAMIC	C-451-220P
C331-334	CAP,100PF, 5%, 100V, CERAMIC	C-465-100P
C336	CAP,1000PF,10%,1000V,CERAMIC	C-64-1000P
C342	CAP, 4.7PF, 5%, 50V, MONO-CERAMIC	C-452-4.7P
C400	CAP,270PF,2.5%,630V,POLYPROPYLENE	C-405-270P
C401	CAPACITOR SMT	C-544-270P
C405, 406	CAP, .15UF,20%,50V, CERAMIC	C-418-.15
C407	CAP, 1UF, 20%, 35V, TANTALUM	C-494-1
C500, 501	CAPACITOR	C-548-.033
C502, 503	CAPACITOR	C-549-.047
C504, 505, 534, 535	CAP, 47UF, 20%, 100V ALUM ELEC	C-521-47
C512, 514	CAP, 22PF, 10%, 100V, CERAMIC	C-451-22P
C515, 541	CAP,.1UF, 20%,50V,CERAMIC	C-418-.1
C522, 523, 526, 544, 527-529, 547, 532, 533	CAPACITOR SMT	C-542-1000P
C539, 540	CAP, 1UF, 20%, 50V CERAMIC	C-519-1
C545, 546	CAP, .022U, 10%, 2000V	C-550-.022
C549, 272	CAP, .1UF, 10%, 25V, CERAMIC	C-495-.1

Table 6-1 (cont.)
Analog board parts list

Circuit designation	Description	Keithley part no.
C605-607, 613, 614, 617-625, 650-652, 659, 660	CAP, .1UF, 10%, 25V, CERAMIC	C-495-.1
C610, 612	CAP, 2200P, 10%, 100V CERAMIC	C-430-2200P
C616	CAP, 22UF, 20%, 25V, TANTALUM	C-440-22
C661, 662, 524, 554, 555, 338, 339, 542, 548	CAP, .1UF, 10%, 25V, CERAMIC	C-495-.1
CR200-203, 205, 207, 208, 210, 216-221, 235	DIODE, SWITCHING, MMBD914	RF-83
CR206, 209, 230-233, 400, 401, 222, 214, 215	DIODE,IN3595	RF-43
CR223	DIODE,IN3595	RF-43
CR224, 225, 504-507	ULTRAFAST POWER RECTIFIER	RF-105
CR236, 204, 211, 212, 213, 513, 522, 602	DIODE, SWITCHING, MMBD914	RF-83
CR237, 238, 512	DIODE, DUAL SWITCHING, BAV99L	RF-82
CR500-503, 523	RECTIFIER	RF-116
CR508-511, 520, 521	DIODE,CONTROLLED AVALANCHE, BYD17GSOD-87	RF-91
CR514, 515, 516	RECTIFIER	RF-125
CR517, 519	RECTIFIER	RF-117
CR600	DIODE, DUAL HSM-2822T31	RF-95
CR601, 524	DIODE, SCHOTTKY, SD103C	RF-113
J1001	CONN,HEADER STRAIGHT SOLDER PIN	CS-368-10
J1002	CONN, HEADER STRAIGHT SOLDER PIN	CS-368-16
J1003	CONNECTOR, HEADER STRAIGHT SOLDER PIN	CS-368-14
J1034	LATCHING HEADER,FRICTON, SGL ROW	CS-724-3
J1035	CONN,BERG	CS-339
K200, 201, 202, 203, 204	RELAY SMT	
K205	N.C RELAY, 1 FORMB, AQV214S	RL-176
K206	RELAY, REED, HI-VOLT/ISOLA- TION,848-1	RL-152
K207, 208	RELAY	RL-199
L201	CHOKE, SHIELD BEAD	CH-52
L600, 601, 602	FERRITE CHIP 600 OHM BLM32A07	CH-62
L603	FERRITE CHIP 600 OHM BLM32A07	CH-62
Q200-207, 240, 241, 232	TRANS, N CHANNEL JFET, SNJ132199	TG-294
Q208, 210, 212, 214, 216, 218	TRANS,NPN CATV SILICON,MPSH17	TG-221
Q209, 211, 213, 215, 217, 219	TRANS,CURRENT REGULATOR,CR430	TG-219

Table 6-1 (cont.)

Analog board parts list

Circuit designation	Description	Keithley part no.
Q220, 225	TRANS,NPN SILICON,MJE340	TG-209
Q221, 226	TRANS,PNP POWER,MJE350	TG-210
Q222, 224	TRANS, N-CHAN JFET, SST4393	TG-263
Q234-239, 244-246, 255, 256, 400, 401, 404, 229	TRANS, N-MOSFET, VN0605T	TG-243
Q242, 243	TRANS, N-CHAN MOSFET, 2SK1412	TG-276
Q258	TRANSISTOR SMT	TG-345
Q259	TRANSISTOR SMT	TG-346
Q260	VERTICAL DMOS FET	TG-301
Q261	TRANS, N-CHAN MOSFET, TN2540N8	TG-274
Q402, 409	TRANS, N-CHAN DMOS FET TN2504N8	TG-261
Q403, 406, 407, 408	TRANS, N-CHAN JFET, SST109	TG-266
Q405,410,411, 602-605, 223, 233	TRANS, N-MOSFET, VN0605T	TG-243
Q412, 414	TRANS, N-MEGAFET, RFD 14N05LSM	TG-267
Q413	TRANS, P-CHAN, MOSFET, TP0610T	TG-259
Q415	TRANS, P-FET, MTP23P06	TG-229
Q501,503,505,508,510, 512,513,227,257	TRANS, NPN, MMBT3904	TG-238
Q504	TRANS, NPN TIP48	TG-314
Q506,520,601,228, 262, 263	TRANS, PNP, MMBT3906L	TG-244
Q507	TRANS, PMP,MJE5731A	TG-315
Q514,516,500,502,230, 231	TRANS, NCHANNEL PWR FET,MTPIN100	TG-222
Q515,517,519,532,600	TRANS, NPN, MMBT3904	TG-238
Q518	TRANS,NPN DARLINGTON, TIP101	TG-230
Q521	TRANS,PNP DARLINGTON, TIP106	TG-231
Q523,531,525,509,533, 511	TRANS, P-CHANNEL FET, MTP2P50	TG-208
Q526, 527	TRANS, N CHANNEL MOSFET, SI9410DY	TG-302
Q528, 265	TRANS, NPN SILICON, BC846BL	TG-278
Q529, 264	TRANS PNP, BC 856BL	TG-287
R125	RESISTOR	R-461-200K
R149	RES, 10K, 5%, 250MW, METAL FILM	R-376-10K
R151,152,536,537, 667-671, 157, 661, 662, 665	RES, 1K, 1%, 100MW, THICK FILM	R-418-1K
R156	RES, 24.9K, 1%, 100MW, THICK FILM	R-418-24.9K
R200,201, 203, 232, 238	RESISTOR NETWORK, 10K-10K	TF-236
R202, 204, 252, 255, 256, 259, 260, 263, 264, 267	RES, 100K, 1%, 100MW THICK FILM	R-418-100K

Table 6-1 (cont.)
Analog board parts list

Circuit designation	Description	Keithley part no.
R207	RES, 90.9K, 1%, 125mW, METAL FILM	R-391-90.9K
R210	RES, 768, 1%, 100MW, THICK FILM	R-418-768
R213	RES NET 5K, .1%, 668A	TF-243-5K
R216, 318, 274-279, 319, 345, 445	RES, 20K, 1%, 100MW THICK FILM	R-418-20K
R217	RES, 121K, 1%, 100MW, THICK FILM	R-418-121K
R218	RES, 80.6K, 1%, 100MW THICK FILM	R-418-80.6K
R219, 220, 230, 231, 616, 482, 221, 483, 373, 374	RES, 49.9K, 1%, 100MW THICK FILM	R-418-49.9K
R222	RES, 66.5K, 1%, 100MW, THICK FILM	R-418-66.5K
R224, 234-237, 244-247, 281, 282, 284-286, 225	RES, 10K, 1%, 100MW, THICK FILM	R-418-10K
R226, 288, 301, 617, 622, 654, 655, 211, 223, 372	RES, 10K, 1%, 100MW, THICK FILM	R-418-10K
R227	RES, 6.04K, 1%, 100MW THICK FILM	R-418-6.04K
R228, 229	RES, 2K, 1%, 100MW, THICK FILM	R-418-2K
R240, 243, 248, 251, 253,	RES, 4.99K, 1%, 100MW THICK FILM	R-418-4.99K
R241, 242, 249, 250, 653, 664	RES, 140K, 1%, 100MW THICK FILM	R-418-140K
R257, 258, 261, 262, 265, 266, 313, 314-317, 366	RES, 4.99K, 1%, 100MW THICK FILM	R-418-4.99K
R268-271, 209	RES, 1M, 1%, 100MW, THICK FILM	R-418-1M
R272, 273	RES, 249K, 1%, 100MW, THICK FILM	R-418-249K
R280, 439, 440	RES, 4.02K, 1%, 100MW, THICK FILM	R-418-4.02K
R283, 287, 297, 299, 350,	RES, 30.1K, 1%, 100MW, THICK FILM	R-418-30.1K
R289, 291	RES, 45.3K, 1%, 100MW THICK FILM	R-418-45.3K
R293	RES, 243K, 1%, 125MW, METAL FILM	R-391-243K
R298, 300	RES, 150K, 1%, 100MW, THICK FILM	R-418-150K
R302	RES, .0499, 1%, 100MW, THICK FILM	R-418-.0499
R303	RES, 3.01K, 1%, 100MW THICK FILM	R-418-3.01K
R304-306	RES, 33, 5%, 250mW, METAL FILM	R-376-33
R311, 312, 334, 337, 339, 335	RES, 4.99K, 1%, 100MW THICK FILM	R-418-4.99K
R320	RESISTOR	R-461-10M
R332, 604, 606, 423, 429, 430, 505, 510, 551	RES, 499, 1%, 100MW THICK FILM	R-418-499
R338, 364, 402-404, 416, 417, 459, 488, 153, 239	RES, 100K, 1%, 100MW THICK FILM	R-418-100K
R340, 343, 361, 362, 365, 369, 336, 353, 480, 481	RES, 1K, 1%, 100MW, THICK FILM	R-418-1K
R341, 342	RES, 13K, 1%, 100MW, THICK FILM	R-418-13K
R346, 370, 294	RESISTOR	R-461-2M
R347	THICK FILM	TF-261

Table 6-1 (cont.)

Analog board parts list

Circuit designation	Description	Keithley part no.
R349, 351	RES, 33.2K, 1%, 100MW, THICK FILM	R-418-33.2K
R358	RES, 3.65K, 1%, 100MW, THICK FILM	R-418-3.65K
R363	THICK FILM	TF-257
R367, 424, 425, 426, 603, 605, 484, 487	RES, 4.99K, 1%, 100MW THICK FILM	R-418-4.99K
R368, 321, 212	RES, 332, 1%, 100MW, THICK FILM	R-418-332
R375, 376, 295, 296	RES, 10, 10%, 100MW, THICK FILM	R-418-10
R377, 378	RES, 33.2K, 1%, 125MW, METAL FILM	R-391-33.2K
R379-387, 391, 392, 308	RES, 475, 1%, 100MW, THICK FILM	R-418-475
R389,390,431-434	RES, 1K, 1%, 100MW, THICK FILM	R-418-1K
R393-399, 411, 412, 413, R422	RES, 357, 1%, 100MW, THICK FILM	R-418-357
R437, 133, 141, 117, 150, 354	RES, 4.7K, 5%, 250MW, METAL FILM RESISTOR	R-376-4.7K R-461-1M
R441, 442	RES, 3.01K, 1%, 100MW THICK FILM	R-418-3.01K
R444	RES, 20K, 1%, 100MW THICK FILM	R-418-20K
R446	RES, 10K, 1%, 100MW, THICK FILM	R-418-10K
R447, 448	RES, 11K, 1%, 100MW, THICK FILM	R-418-11K
R450	RES, 2.0M, .1%, 1/4W METAL FILM	R-321-2M
R451	RES,221K, 1%, 1/10W, METAL FILM	R-263-221K
R452	RES, 20K, .5%, 1/8W, METAL FILM	R-351-20K
R453	RES, 1.8K, .1%, 1/10W, METAL FILM	R-263-1.8K
R454, 455	RES, 49.9, .1%, 1/10W METAL FILM	R-263-49.9
R467-471	RES, 100, .1%, 1/10W, METAL FILM	R-263-100
R472, 478, 466, 355, 290, 344,309	RES, 1K, 1%, 100MW, THICK FILM	R-418-1K
R473	RES, 30.1K, 1%, 100MW, THICK FILM	R-418-30.1K
R474-477	RES, .2, 1%, 1W	R-441-.2
R479, 501, 529, 530, 534, 563	RES, 249,1%, 100MW, THICK FILM	R-418-249
R485, 525, 526, 552, 348	RES, .0499, 1%, 100MW, THICK FILM	R-418-.0499
R489, 356, 359, 418-421, 456, 458, 460, 462, 464	RES, 1K, 1%, 100MW, THICK FILM	R-418-1K
R490	RES, 205, .1%, 1/10W, METAL FILM	R-263-205
R500, 508, 521, 527, 528, 533, 535, 549, 566, 567	RES, 562K, 1%, 125MW, METAL FILM	R-391-562K
R502, 513, 515, 561, 562, 565, 569-573	RES, 562K, 1%, 125MW, METAL FILM	R-391-562K
R503, 512, 514, 532, 560	RES, 249,1%, 100MW, THICK FILM	R-418-249
R504, 511RES, 10K, 1%, 100MW, THICK FILM		
R506	RES, 30.1, 1%, 1/8W METAL FILM	R-88-30.1
R507	RES, 18.7, 1%, 125mW, METAL FILM	R-391-18.7

Table 6-1 (cont.)
Analog board parts list

Circuit designation	Description	Keithley part no.
R509	RES, 18.7, 1%, 125mW, METAL FILM	R-391-18.7
R516, 523	RES, 4.02K, 1%, 100MW,, THICK FILM	R-418-4.02K
R517, 539-541	RES, 12.1, 1%, 125MW METAL FILM	R-391-12.1
R520	RES, 301, 1%, 100MW, THICK FILM	R-418-301
R524, 538	RES, 12.1, 1%, 125MW METAL FILM	R-391-12.1
R531	RES, 301, 1%, 100MW, THICK FILM	R-418-301
R542, 543	RES,,.5,5%,1W, METAL	R-444-.5
R544-547, 292	RES, 100K, 1%, 100MW THICK FILM	R-418-100K
R548	RES, 30.1K, 1%, 100MW, THICK FILM	R-418-30.1K
R550, 435, 436	RES, 499, 1%, 100MW THICK FILM	R-418-499
R555	RES, 7.32K, .1%, .125MW, THIN FILM	R-456-7.32K
R556	RES, 42.7K, .1%, .125W, THIN FILM	R-456-42.7K
R557	RES, 17.2K, .1%, .125W, THIN FILM	R-456-17.2K
R559	RES, 1.5K, 1%, 100MW THICK FILM	R-418-1.5K
R568, 574, 575	RES, 562K, 1%, 125MW, METAL FILM	R-391-562K
R600, 449	RES, 100K, 1%, 100MW THICK FILM	R-418-100K
R602, 607, 558	RES, 1.5K, 1%, 100MW THICK FILM	R-418-1.5K
R609	RES NET	TF-245
R610	RES, 1.28M, .1%, 1/8W METAL FILM	R-176-1.28M
R611, 621	RES, 475, 1%, 100MW, THICK FILM	R-418-475
R612	RES, 5.11K, 1%, 100MW, THICK FILM	R-418-5.11K
R613, 624, 659, 660, 518, 519	RES, 100, 1%, 100MW, THICK FILM	R-418-100
R614, 615, 208, 553, 554	RES, 2.21K, 1%, 100MW, THICK FILM	R-418-2.21K
R618	RES, 34K, 1%, 100MW, THICK FILM	R-418-34K
R619	RES, 4.75K, 1%, 100MW, THICK FILM	R-418-4.75K
R620	RES, 82.5, 1%, 100MW, THICK FILM	R-418-82.5
R623, 154, 155	RES, 10, 10%, 100MW, THICK FILM	R-418-10
R650 ,651	RES NET, 9K-1K, MICRO DIVIDER	TF-246-2
R652, 665	RES, 357, 1%, 100MW, THICK FILM	R-418-357
R656	RES, 8.98K, .1%,.125W THIN FILM	R-456-8.98K
R657, 658	RES, 1M, 1%, 100MW, THICK FILM	R-418-1M
R666	RES NET, 3K, 12K, 0.1%, 100MW THIN-FILM	TF-237-2
RT200	POLY SWITCH, PTC RESISTOR	RT-17
T500	TRANSFORMER	TR-311A
TP200-215, 218-225, 227, 228, 230-235, 500	CONN,TEST POINT	CS-553
TP501, 506-510	CONN,TEST POINT	CS-553
U201, 212, 214, 230, 241, 400-406, 652	IC, CMOS ANAL SWITCH, DG444DY	IC-866
U202, 650, 203	IC, OP AMP LT1112	IC-1048

Table 6-1 (cont.)

Analog board parts list

Circuit designation	Description	Keithley part no.
U204, 229	IC, 8-CHAN ANA MULTI- PLEXER,DG408DY	IC-844
U205, 407	IC, HEX INVERTERS, 74HC400	IC-880
U209, 215	IC, QUAD COMPARATOR,LM339D	IC-774
U210, 220	IC, DUAL BIPOLAR OP-AMP, LT1124CS8	IC-955
U211, 213	IC, BIFET OP AMP, AD712JR	IC-834
U221, 227	IC, DIFF. AMP, AMP03GP	IC-988
U222	IC, OP-AMP, LTC1050CS8	IC-791
U223, 409, 237	IC, MOSFET DRIVER, TLP591B	IC-877
U226, 659	IC, 20V OP-AMP, LT1097S8	IC-767
U231, 219, 235, 234, 262, 232	IC, OP AMP, LOW POWER AD795JR	IC-1052
U238	IC, CMOS ANA SWITCH SPST MAX326CSE	IC-909
U239	IC, QUAD 2-INPUT NAND, 74HC00M	IC-781
U240	IC,POS NAND GATES/INVERT,74HCT14	IC-656
U242-247	IC,DUAL HIGH CMR/SPEED OPTO,HCPL-2631	IC-588
U252-256	IC 8 STAGE SHIFT CD74HC4094M	IC-1026
U257	IC, SUPPLY VOLT SUPERVI- SOR,TL7705A	IC-860
U263, 228	IC, OP-AMP, LOW NOISE LT1007CS8	IC-949
U265	IC, PHOTO TRANS, TLP626BV-LFI	IC-1006
U408, 218, 216, 225	ICM DUAL J-FET OP-AMP, OP-282GS	IC-968
U500	IC, OP-AMP, AD847JN	IC-890
U501	IC, VOLT COMPARATOR LM393D	IC-775
U502	PROGRAMMABLE TEMP CONTROLLER	IC-1062
U600, 264, 206, 207, 208, 233	IC, DUAL PICOAMP OP-AMP AD706JR	IC-910
U601	IC,QUAD D FLIP FLOP W/CLK,RESET 74HC175	IC-923
U604	IC, NCHAN LAT DMOS QUADFET, SD5400CY	IC-893
U605	INTEGRATED CIRCUIT, OPA177GS	IC-690
U606, 236	IC, HI-SPEED BIFET OP-AMP, AD711JR	IC-894
U607	IC, OP-AMP, NE5534D	IC-802
U608	IC, VOLT. COMPARATOR,LM311M	IC-776
U609	PROGRAMMED IC	2400-801-*
U651, 602, 603, 224	IC, QUAD 2 IN NOR, 74HCT02	IC-809
U660, 661	IC, 16 BIT DAC, AD7849BR	IC-1004
VR200, 201	DIODE, ZENER MM524694	DZ-113
VR214, 215, 504, 505, 506	DIODE, ZENER, 8.2V, MMBZ5237	DZ-92
VR216, 217, 650, 651	DIODE, ZENER 17V, MMBZ5247BL	DZ-104

Table 6-1 (cont.)*Analog board parts list*

Circuit designation	Description	Keithley part no.
VR218, 219	DIODE, ZENER 30V BZX84C30	DZ-106-30
VR400, 401	DIODE, ZENER 4.7V, IN4732A	DZ-67
VR403, 601, 604	DIODE, ZENER 3.3V, MMBZ5226BL	DZ-94
VR404-406, 202, 203	DIODE,ZENER 5.1V, BZX84C5V1	DZ-88
VR500, 501	DIODE, ZENER 6.0V, BZX84B6V2	DZ-87
VR502, 503	DIODE ZENER 12V, MMSZ12T1	DZ-112
VR507	DIODE, ZENER 22V, BZX84C22	DZ-86
VR508, 509	DIODE, ZENER 9.1V, IN4739A	DZ-56
VR600	DIODE,ZENER 6.4V, IN4579	DZ-73
VR602, 603	DIODE, ZENER, 6.2V MMSZ6V2	DZ-97
Y600	OSCILLATOR HIGH SPEED CMOS 12MHZ	CR-37

* Order current firmware revision, for example A01.

Table 6-2*Digital board parts list*

Circuit designation	Description	Keithly part no.
BT1	BATTERY	BA-46
C1, 3, 77, 11-14, 16, 17, 20, 22, 23, 25, 26, 30, 40	CAP, .1UF, 10%, 25V, CERAMIC	C-495-.1
C2, 56, 8, 76, 78, 80, 82, 89	CAP, .01UF, 10%, 50V CERAMIC	C-491-.01
C4, 10	CAP, 15P, 1%, 100V CERAMIC	C-512-15P
C5	CAP, .1UF, 20%, 100V, CERAMIC	C-436-.1
C15, 38, 61, 47	CAP, 47P, 5%, 100V, CERAMIC	C-465-47P
C19, 85, 41, 69, 70, 71, 73, 24	CAP, .1UF, 10%, 25V, CERAMIC	C-495-.1
C28, 60	CAP, 47P, 5%, 100V, CERAMIC	C-465-47P
C31	CAP, 100PF, 5%, 100V, CERAMIC	C-465-100P
C32, 34, 63, 64	CAP, 47UF, 20%, 100V ALUM ELEC	C-521-47
C33, 35, 52-55	CAP, 22UF, 20%, 25V, TANTALUM	C-440-22
C36, 50, 39, 44-46, 49, 59, 66-68, 79, 81, 48, 83	CAP, .1UF, 10%, 25V, CERAMIC	C-495-.1
C42, 43, 97-99, 101, 102, 104	CAP, .1UF, 20%, 50V, CERAMIC	C-418-.1
C57, 58	CAP, 1000PF, 10%, 50V, MONO CERAMIC	C-452-1000P
C62, 91	CAP, 10UF, 20%, 25V, TANTALUM	C-440-10
C65	CAP, .022UF, 10%, 50V CERAMIC	C-491-.022
C72, 86	CAP, 1UF, 20%, 50V CERAMIC	C-519-1
C74, 75	CAP, 470UF, 20%, 25V ALUM ELEC	C-413-470
C84, 6, 7, 9, 18, 90	CAP, .1UF, 10%, 25V, CERAMIC	C-495-.1
C87, 88	CAP, .01UF, 10%, 50V CERAMIC	C-491-.01
C96, 100, 103, 105	CAP, .1UF, 20%, 50V, CERAMIC	C-418-.1
C106, 107	CAP, 1UF, 20%, 100V, CERAMIC	C-487-1
CR1-4	ULTRAFAST POWER RECTIFIER	RF-107
CR6, 9, 12, 20	ULTRAFAST POWER RECTIFIER	RF-105
CR8, 11, 17, 21, 25-28, 31, 19	DIODE, SWITCHING, 250MA, BAV103	RF-89
CR13	DIODE, DUAL HSM-2822T31	RF-95
CR14, 15, 22-24, 5, 32, 33	DIODE, DUAL SWITCHING, BAV99L	RF-82
CR29, 30, 34-39	DIODE, SWITCHING, MMBD914	RF-83
F1	POLY SWITCH, SMD030-2	FU-103
HS1, 2, 3	HEAT SINK	HS-33
IC1	IC, POS VOLTAGE REG +15V, 500MA, 78M15	
J1	CONN, RIGHT ANGLE, 24PIN	CS-507
J2, 4	CONN, BERG	CS-339
J3	CONN, RT ANGLE, MALE, 9 PIN	CS-761-9
J5	CONN, MICRODIN W/GND FINGERS	CS-792
J6	CONN, D-SUB MALE, BOARDLOCK TYPE	CS-848-9
J21	CONN, MOLEX, 3-PIN	CS-772-3

Table 6-2 (cont.)
 Digital board parts list

Circuit designation	Description	Keithly part no.
K1	RELAY, SURFACE MOUNT	RL-188
L1	FERRITE CHIP 600 OHM BLM32A07	CH-62
LS1	BEEPER, 5V, 30MA, QMX-05	EM-6
P1001	CABLE ASSEMBLY	CA-152-1
P1003	CABLE ASSEMBLY	CA-32-9B
P1004, 1002	CABLE ASSEMBLY	CA-62-4B
Q1-6	TRANS, N-MOSFET, VN0605T	TG-243
Q7,8	POWER MOSFET IRFZ346	TG-313
Q10	TRANS, NPN, MMBT3904	TG-238
R1,37	RES, 2.21K, 1%, 100MW, THICK FILM	R-418-2.21K
R2, 13, 4, 52, 14, 19, 34, 35, 50, 58, 63, 68, 62, 75	RES, 10K, 1%, 100MW, THICK FILM	R-418-10K
R5	RES, 10M, 1%, 125MW, THICK FILM	R-418-10M
R6, 47, 60, 84, 41	RES, 10K, 1%, 100MW, THICK FILM	R-418-10K
R9, 11, 12, 16, 20	RES, 100, 5%, 250MW, METAL FILM	R-376-100
R10	RES, 332K, 1%, 100MW, THICK FILM	R-418-332K
R15, 17, 21, 23, 31, 70, 72, 18, 64, 59, 48, 61, 8	RES, 1K, 1%, 100MW, THICK FILM	R-418-1K
R25, 28, 49	RES, 4.75K, 1%, 100MW, THICK FILM	R-418-4.75K
R30, 26	RES, 100, 1%, 100MW, THICK FILM	R-418-100
R33, 39	RES, .0499, 1%, 100MW, THICK FILM	R-418-.0499
R38	RES, 11K, 1%, 100MW, THICK FILM	R-418-11K
R40, 32, 27, 24	RES, 5.1K, 5%, 125MW, METAL FILM	R-375-5.1K
R43, 44, 45, 65	RES, 2.21K, 1%, 100MW, THICK FILM	R-418-2.21K
R51	RES, 7.5K, 1%, 125MW, METAL FILM	R-391-7.5K
R53, 54	RES, 3.01K, 1%, 100MW THICK FILM	R-418-3.01K
R55	RES, 10M, 1%, 125MW, THICK FILM	R-418-10M
R56	RES, 3.01K, 1%, 100MW THICK FILM	R-418-3.01K
R57	RES, 1M, 1%, 100MW, THICK FILM	R-418-1M
R73, 74, 76, 78-81, 83, 7, 69, 71, 85-89	RES, 10K, 1%, 100MW, THICK FILM	R-418-10K
R77	RES, 15k, 1%, 100MW, THICK FILM	R-418-15K
R82	RES, 499, 1%, 100MW THICK FILM	R-418-499
R91, 92	RES, 200, 1%, 100MW, THICK FILM	R-418-200
S01, 2	SOCKET PLCC-032-T-A	SO-143-32
S1	SWITCH, PUSHBUTTON (6 POLE)	SW-466
T1	TRANSFORMER FOR F SUPPLIES	TR-302B
TP3	CONN, TEST POINT	CS-553
U1, 22	IC, DUAL D-TYPE F/F, 74HC74	IC-773
U2	IC, MICROMANAGER, DS12365-10	IC-884
U3	MICROCONTROLLER, MC68332-FC	LSI-161
U4	IC +5V RS-232 TRANSCEIVER, MAX202	IC-952
U5	IC, OP-AMP, AD705JR	IC-814

Table 6-2 (cont.)
Digital board parts list

Circuit designation	Description	Keithly part no.
U6	IC,OCTAL INTER BUS TRANS,75161	IC-647
U7	IC, 4-CHANNEL PWR DRIVER, 2549B	IC-1044
U8	IC, NEG VOLTAGE REG -15V, 500MA, 79M15	
U9	IC, HEX INVERTERS, 74HCT04	IC-880
U11	IC, VOLT COMPARATOR LM393D	IC-775
U12, 14	LARGE SCALE IC	LSI-162-70
U13	IC, GPIB ADAPTER, 9914A	LSI-123
U15	PROGRAMMED ROM	2400-803-*
U16	PROGRAMMED ROM	2400-804-*
U17	IC, SERIAL EPROM 24LC16B	LSI-153
U18	IC,+5V VOLTAGE REGULATOR,	LM2940CT
U19	IC, SCHMITT-TRIGGER NAND GATE	IC-950
U20	IC,OCTAL INTERFACE BUS,75160	IC-646
U21	IC, DUAL POWER MOSFET DRIVER, TSC426	IC-437
U23, 25	IC, POS NAND GATES/INVERT, 74HCT14	IC-656
U24	IC, TRIPLE 3 IN NAND, 74F10	IC-659
VR1	DIODE, ZENER 33V, IN4752A	DZ-68
Y1	CRYSTAL, FSM327	CR-41

*Order current firmware revision, for example A03.

Table 6-3
Display board parts list

Circuit designation	Description	Keithley part no.
C901	CAP, 22UF, 20%, 6.3, TANTALUM	C-417-22
C902, 904, 907, 908, 910	CAP, .1UF, 20%,100V, CERAMIC	C-436-.1
C903, 905, 906, 909, 911	CAP,.1UF, 20%,50V, CERAMIC	C-418-.1
C912	CAP, 2.2UF, 20%,100V, ALUM ELEC	C-503-2.2
C913, 914	CAP, 100UF, 20%,16V, TANTALUM	C-504-100
C915, 916	CAP, 33PF, 10%, 100V, CERAMIC	C-451-33P
CR901-904	DIODE, SWITCHING, 250MA, BAV103	RF-89
CR905, 906	DIODE, SWITCHING, MMBD914	RF-83
DS901	VACUUM FLUORESCENT DISPLAY	DD-51C
J1032	CONN, BERG	
J1033	CONN, HEADER STRAIGHT SOLDER PIN	CS-368-16
Q901, 902	TRANS, NPN GEN PURPOSE BC868	TG-293
R901	RES NET, 15K, 2%, 1.875W	TF-219-15K
R902	RES, 13K, 5%,125MW, METAL FILM	R-375-13K
R903, 904	RES, 4.7K, 5%, 250MW, METAL FILM	R-376-4.7K
R905	RES, 1M, 5%, 125MW, METAL FILM	R-375-1M
R906	RES,1K, 5% 250MW, METAL FILM	R-376-1K
R907	RES, 240, 5%, 250MW, METAL FILM	R-376-240
R908	RES, 10M, 5%, 125MW, METAL FILM	R-375-10M
T901	TRANSFORMER, TDK, ER14.5 SERIES	TR-300
U901,904,905	IC, LATCHED DRIVERS,UCN-5812EPF-1	IC-732
U902	IC, PROGRAMMED	7001-800-*
U903	IC, 32-BIT, SERIAL UCN5818EPF-1	IC-830
VR901	DIODE, ZENER, 8.2V, MMBZ5237	DZ-92
Y901	CRYSTAL, 4MHZ	CR-36-4M

* Order current firmware revision. For example, 7001-800-A02.

Table 6-4
Mechanical parts list

Quantity	Description	Keithley part no.
4	BANANA JACK, PUSH-IN, BLACK	BJ-13-0
1	BANANA JACK, PUSH-IN, BLUE	BJ-13-6
4	BANANA JACK, PUSH-IN, RED	BJ-13-2
1	BANANA JACK, PUSH-IN, WHITE	BJ-13-9
1	BEZEL, REAR	428-303D
1	BOTTOM SHIELD	2400-309A
4	CHOKE	CH-58-1A
1	COVER	2400-317B
1	DISPLAY LENS	2410-311B
2	FOOT, EXTRUDED	FE-22A
2	FOOT, RUBBER	FE-6
1	FUSE, 2.5A 5 X 20MM	FU-106-2.5
1	HANDLE	428-329F
1	HEAT SINK	2400-308E
2	HOLDER, FERRITE	2001-367A
1	LED, HIGH POWER	PL-94
1	LENS, LED	6517-309A
1	LINE CORD	CO-7
1	LINE FILTER	LF-11
1	MEMBRANE SWITCH, FRONT PANEL	2410-313B
1	MOUNTING EAR, LEFT	428-338B
1	MOUNTING EAR, RIGHT	428-328E
1	POWER SUPPLY	PS-41B
1	SWITCHPAD	2400-315A
1	TEST LEADSET	CA-23

A Specifications

Accuracy calculations

The information below discusses how to calculate accuracy for both measurement and source functions.

Measurement accuracy

Measurement accuracy is calculated as follows:

$$\text{Accuracy} = \pm(\% \text{ of reading} + \text{offset})$$

As an example of how to calculate the actual reading limits, assume that you are measuring 10V on the 20V range. You can compute the reading limit range from one-year measure voltage accuracy specifications as follows:

$$\begin{aligned}\text{Accuracy} &= \pm(\% \text{ of reading} + \text{offset}) \\ &= \pm[(0.015\% \times 10\text{V}) + 1\text{mV}] \\ &= \pm(1.5\text{mV} + 1\text{mV}) \\ &= \pm 2.5\text{mV}\end{aligned}$$

Thus, the actual reading range is $10\text{V} \pm 2.5\text{mV}$ or from 9.9975 to 10.0025V.

Current measurement calculations are performed in exactly the same manner using the pertinent specifications, ranges, and input signal values.

Source accuracy

Source accuracy is calculated similarly, except of course that source specifications are used. As an example of how to calculate the actual source output limits, assume that you are sourcing 0.7mA on the 1mA source range. You can compute the reading limit range from source current one-year accuracy specifications as follows:

$$\begin{aligned}\text{Accuracy} &= \pm(0.034\% \text{ of output} + 200\text{nA offset}) \\ &= \pm[(0.034\% \times 0.7\text{mA}) + 200\text{nA}] \\ &= \pm(238\text{nA} + 200\text{nA}) \\ &= \pm 438\text{nA}\end{aligned}$$

In this case, the actual current output range is $0.7\text{mA} \pm 438\text{nA}$ or from 0.69956mA to 0.70044mA.

B Command Reference

Introduction

This appendix contains detailed information on the various Model 2410 remote calibration commands, calibration error messages, and methods to detect the end of each calibration step.

Section 2 of this manual covers detailed calibration procedures.

Command summary

Table B-1 summarizes Model 2410 calibration commands. These commands are covered in detail in the following paragraphs.

Table B-1
Remote calibration command summary

Command	Description
CALibration	Calibration subsystem.
:PROTeCted	Cal commands protected by password.
:CODE '<password>'	Unlock cal; if cal is unlocked, changes password. (Default password: KI002410.)
:COUNT?	Query number of times 2410 has been calibrated.
:SAVE	Save calibration data to EEPROM.*
:LOCK	Lock calibration, inhibit SAVE command operation.
:LOCK?	Request cal lock status. (0 = unlocked; 1 = locked.)
:DATE <y>,<m>,<d>	Program calibration year, month, day.
:DATE?	Query calibration year, month, day.
:NDUE <y>,<m>,<d>	Program calibration due year, month, day.
:NDUE?	Query calibration due year, month, day.
:SENSe <nrf>	Calibrate active measure range.
:DATA?	Query measurement cal constants for active range.
:SOURce <nrf>	Calibrate active source range.
:DATA?	Query measurement cal constants for active range.

*Calibration data will not be saved if:

1. Calibration was not unlocked with :CODE command.
2. Invalid data exists. (For example, cal step failed or was aborted.)
3. Incomplete number of cal steps were performed. (For example, omitting a negative full-scale step.)

Miscellaneous commands

Miscellaneous commands are those commands that perform such functions as saving calibration constants, locking out calibration, and programming date parameters.

:CODE

(:CALibration:PROTected:CODE)

Purpose	To unlock calibration so the calibration procedures can be performed.
Format	:cal:prot:code '<password>'
Parameters	Up to an 8-character string including letters and numbers.
Description	The :CODE command sends the password and enables calibration when performing these procedures via remote. The correct password must be sent to the unit before sending any other calibration command. The default remote password is KI002410.
Note	<ul style="list-style-type: none">• The :CODE command should be sent only once before performing calibration. Do not send :CODE before each calibration step.• To change the code, first send the present code, and then send the new code.• The password parameter must be enclosed in single quotes.• If you change the first two characters of the password to something other than "KI," you will not be able to unlock calibration from the front panel.
Example	:CAL:PROT:CODE 'KI002410' Send default code of KI002410.

:COUNT?

(:CALibration:PROTected:COUNT?)

Purpose	To request the number of times the Model 2410 has been calibrated.
Format	:cal:prot:count?
Response	Number of times calibrated.
Description	The :COUNT? query can be used to determine the total number of times the Model 2410 has been calibrated.
Example	:CAL:PROT:COUNT? Request calibration count.

:LOCK**(:CALibration:PROTeCted:LOCK)**

Purpose	To lock out calibration.	
Format	:cal:prot:lock	
Query	:cal:prot:lock?	
Response	0	Calibration unlocked
	1	Calibration locked
Description	The :LOCK command lets you lock out comprehensive calibration after completing those procedures. Thus, :LOCK performs the opposite of sending the password with the :CODE command. The :LOCK? query returns calibration lock status.	
Note	To unlock calibration, send the :CODE command with the appropriate password.	
Example	:CAL:PROT:LOCK	Lock out calibration

:SAVE**(:CALibration:PROTeCted:SAVE)**

Purpose	To save calibration constants in EEROM after the calibration procedure.	
Format	:cal:prot:save	
Description	The :SAVE command stores internally calculated calibration constants derived during comprehensive in EEROM. EEROM is non-volatile memory, and calibration constants will be retained indefinitely once saved. Generally, :SAVE is sent after all other calibration steps (except for :LOCK).	
Note	Calibration will only be temporary unless the :SAVE command is sent to permanently store calibration constants. Calibration data will not be saved if: (1) calibration was not unlocked by sending the :CODE command, (2) invalid data exists (for example, cal step failed or was aborted), or (3) an incomplete number of cal steps were performed (for example, omitting a negative full-scale step).	
Example	:CAL:PROT:SAVE	Save calibration constants

:DATE

(:CALibration:PROTeCted:DATE)

Purpose	To program the calibration date.
Format	:cal:prot:date <year>, <month>, <day>
Parameters	<year> = 1996 to 2095 <month> = 1 to 12 <day> = 1 to 31
Query	:cal:prot:date?
Response	<year>, <month>, <day>
Description	The :DATE command allows you to store the calibration date in instrument EEROM for future reference. You can read back the date from the instrument by using the :DATE? query or by using the front panel CAL menu.
Note	The year, month, and day parameters must be delimited by commas.
Example	:CAL:PROT:DATE 1996,11,20 Send cal date (11/20/96).

:NDUE

(:CALibration:PROTeCted:NDUE)

Purpose	To send the next calibration due date to the instrument.
Format	:cal:prot:ndue <year>, <month>, <day>
Parameters	<year> = 1996 to 2095 <month> = 1 to 12 <day> = 1 to 31
Query	:cal:prot:ndue?
Response	<year>, <month>, <day>
Description	The :NDUE command allows you to store the date when calibration is next due in instrument memory. You can read back the next due date by using the :NDUE? query or by using the front panel CAL menu.
Note	The next due date parameters must be delimited by commas.
Example	:CAL:PROT:NDUE 1997,11,20 Send due date (11/20/97).

Table B-2*Recommended :CALibration:PROTeCted:SENSe parameter ranges*

Sense range	First parameter (zero)	Second parameter (negative full scale)	Third parameter (positive full scale)
0.2V	-0.002 to +0.002	-0.18 to -0.22	+0.18 to +0.22
2V	-0.02 to +0.02	-1.8 to -2.2	+1.8 to +2.2
20V	-0.2 to +0.2	-18 to -22	+18 to +22
1000V	-2 to +2	-800 to -1100	+800 to +1100
1 μ A	-1E-8 to +1E-8	-0.9E-6 to -1.1E-6	+0.9E-6 to +1.1E-6
10 μ A	-1E-7 to +1E-7	-9E-6 to -11E-6	+9E-6 to +11E-6
100 μ A	-1E-6 to +1E-6	-90E-6 to -110E-6	+90E-6 to +110E-6
1mA	-1E-5 to +1E-5	-0.9E-3 to -1.1E-3	+0.9E-3 to +1.1E-3
20mA	-1E-4 to +1E-4	-18E-3 to -22E-3	+18E-3 to +22E-3
100mA	-1E-3 to +1E-3	-90E-3 to -110E-3	+90E-3 to +110E-3
1A	-1E-2 to +1E-2	-0.9 to -1.1	+0.9 to +1.1

Note: Actual allowable parameter ranges are $\pm 50\%$ of full range for zero parameters, 75% of full scale to 150% of full scale for full-range parameters, but ranges listed above should be observed for optimum calibration.

:SOURce**(:CALibration:PROTeCted:SOURce)**

Purpose	To calibrate the source function.
Format	:cal:prot:sour <nrf>
Parameters	See Table B-3 for recommended parameter ranges.
Description	The :CAL:PROT:SOUR command calibrates the Model 2410 source function. To use this command, you must (1) program the source to the correct value, (2) select the range being calibrated, and (3) send the :CAL:PROT:SOUR command for each parameter listed in Table B-3.
Note	<p>When the Model 2410 receives this command, it will attempt to place the parameter into one of the four parameter ranges summarized in Table B-3, depending on the active :SOUR:FUNC and range. If the parameter does not fit into any of the four allowed ranges, error number -222, "Parameter data out of range," will be generated. Once the unit has successfully selected the appropriate parameter range, it will then check to see if the active source is programmed to a value within the selected parameter range and that :OUTP:STAT is ON. If the active source is not programmed to a value within the parameter range (or if the source is in autorange or in standby), error number -221, "Settings conflict," will be generated. If no error occurs, the active source function/range point will be calibrated using the corresponding parameter.</p> <p>Note that parameters for a given source function and range may be sent in any order. However, once one :CAL:PROT:SOUR command executes, the other three must also be executed, or error number -200, "Execution error," will occur when the :CAL:PROT:SAVE command is processed at the end of the calibration procedure.</p> <p>Because the source is calibrated for both positive and negative values, two zero calibration points are required. The Model 2410 automatically uses the appropriate zero parameter based on whether the source polarity is positive or negative.</p>
Example	:CAL:PROT:SOUR 2 Calibrate 2V source range.

Table B-3*Recommended :CALibration:PROTected:SOURce parameter ranges*

Source range	First parameter (negative full scale)	Second parameter (negative zero)	Third parameter (positive full scale)	Fourth parameter (positive zero)
0.2V	-0.18 to -0.22	-0.002 to +0.002	+0.18 to +0.22	-0.002 to +0.002
2V	-1.8 to -2.2	-0.02 to +0.02	+1.8 to +2.2	-0.02 to +0.02
20V	-18 to -22	-0.2 to +0.2	+18 to +22	-0.2 to +0.2
1000V	-800 to -1100	-2 to +2	+800 to +1100	-2 to +2
1 μ A	-0.9E-6 to -1.1E-6	-1E-8 to +1E-8	+0.9E-6 to +1.1E-6	-1E-8 to +1E-8
10 μ A	-9E-6 to -11E-6	-1E-7 to +1E-7	+9E-6 to +11E-6	-1E-7 to +1E-7
100 μ A	-90E-6 to -110E-6	-1E-6 to +1E-6	+90E-6 to +110E-6	-1E-6 to +1E-6
1mA	-0.9E-3 to -1.1E-3	-1E-5 to +1E-5	+0.9E-3 to +1.1E-3	-1E-5 to +1E-5
20mA	-18E-3 to -22E-3	-1E-4 to +1E-4	+18E-3 to +22E-3	-1E-4 to +1E-4
100mA	-90E-3 to -110E-3	-1E-3 to +1E-3	+90E-3 to +110E-3	-1E-3 to +1E-3
1A	-0.9 to -1.1	-1E-2 to +1E-2	+0.9 to +1.1	-1E-2 to +1E-2

Note: Actual allowable parameter ranges are $\pm 50\%$ of full range for zero parameters, 75% of full scale to 150% of full scale for full-range parameters, but ranges listed above should be observed for optimum calibration.

:DATA?**(:CALibration:PROTeCted:SENSe:DATA?)****(:CALibration:PROTeCted:SOURce:DATA?)**

Purpose	To request the calibration constants for the active range.	
Format	:cal:prot:sens:data? :cal:prot:sour:data?	
Response	Four comma-separated ASCII floating-point constants.	
Description	The :CAL:PROT:SENS:DATA? and :CAL:PROT:SOUR:DATA? queries request the calibration constants for the active range of the sense and source functions respectively. The four returned constants are in ASCII floating-point format delimited by commas.	
Note	To request the appropriate constants, (1) select the source or sense function, (2) choose the desired range, and (3) send the desired :DATA? query.	
Example	:SENS:FUNC 'VOLT:DC'	Select DC sense function.
	:SENS:VOLT:DC:RANGE 0.2	Choose 200mV range.
	:CAL:PROT:SENS:DATA?	Request cal constants.

Detecting calibration errors

If an error occurs during any calibration step, the Model 2410 will generate an appropriate error message. Several methods to detect calibration errors are discussed below.

Reading the error queue

As with other Model 2410 errors, any calibration errors will be reported in the error queue. (You can read the error queue by using the `:SYST:ERR?` query.)

Error summary

Table B-4 summarizes calibration errors. These errors will occur under the following conditions.

Error 500/501	These errors occur if you do not set the calibration date or calibration due date.
Error 502	This error will occur when the <code>:CAL:PROT:SENS</code> or <code>:CAL:PROT:SOUR</code> command is sent with a parameter that cannot be placed into any of the defined numeric ranges.
Error 503/504	This error occurs when the source/compliance DAC calibration constants generate an invalid DAC setting. All of the source/compliance DAC calibration constants are verified each time a <code>:CAL:PROT:SOUR</code> command is processed and when the Model 2410 is first turned on. This error generally occurs when the Model 2410 source circuitry is defective.
Error 505	This error occurs when a <code>:CAL:PROT:SOUR</code> command generates an invalid source offset calibration constant.
Error 506	This error occurs when a <code>:CAL:PROT:SOUR</code> command generates an invalid source gain calibration constant.
Error 507	This error occurs when a <code>:CAL:PROT:SENS</code> command generates an invalid measurement offset calibration constant.
Error 508	This error occurs when a <code>:CAL:PROT:SENS</code> command generates an invalid measurement gain calibration constant.

Table B-4
Calibration errors

Error number	Error message
+500	"Date of calibration not set"
+501	"Next date of calibration not set"
+502	"Calibration data invalid"
+503	"DAC calibration overflow"
+504	"DAC calibration underflow"
+505	"Source offset data invalid"
+506	"Source gain data invalid"
+507	"Measurement offset data invalid"
+508	"Measurement gain data invalid"

Status byte EAV (Error Available) bit

Whenever an error is available in the error queue, the EAV (Error Available) bit (bit 2) of the status byte will be set. Use the *STB? query to obtain the status byte, and then test bit 2 to see if it is set. If the EAV bit is set, an error has occurred, and you can use the appropriate error query to read the error and at the same time clear the EAV bit in the status byte.

Generating an SRQ on error

To program the instrument to generate an IEEE-488 bus SRQ (Service Request) when an error occurs, send the *SRE 4 command. This command will enable SRQ when the EAV bit is set. You can then read the status byte and error queue as outlined above to check for errors and to determine the exact nature of the error.

Detecting calibration step completion

When sending remote calibration commands, you must wait until the instrument completes the present operation before sending another command. You can use either `*OPC?` or `*OPC` to help determine when each calibration step is completed.

Using the `*OPC?` query

With the `*OPC?` (operation complete) query, the instrument will place an ASCII 1 in the output queue when it has completed each step. To determine when the OPC response is ready, perform the following:

1. Repeatedly test the MAV (Message Available) bit (bit 4) in the status byte and wait until it is set. (You can request the status byte by using the `*STB?` query.)
2. When MAV is set, a message is available in the output queue, and you can read the output queue and test for an ASCII 1.
3. After reading the output queue, repeatedly test MAV again until it clears. At this point, the calibration step is completed.

Using the `*OPC` command

The `*OPC` (operation complete) command can also be used to detect the completion of each calibration step. In order to use `*OPC` to detect the end of each calibration step, perform the following:

1. Enable operation complete by sending `*ESE 1`. This command sets the OPC (operation complete bit) in the standard event enable register, allowing operation complete status from the standard event status register to set the ESB (event summary bit) in the status byte when operation complete is detected.
2. Send the `*OPC` command immediately following each calibration command. For example:

```
:CAL:PROT:SENS 2;*OPC
```

Note that you must include the semicolon (;) to separate the two commands and that the `*OPC` command must appear on the same line as the command.

3. After sending a calibration command, repeatedly test the ESB (Event Summary) bit (bit 5) in the status byte until it is set. (Use `*STB?` to request the status byte.)
4. Once operation complete has been detected, clear OPC status using one of two methods: (1) use the `*ESR?` query, and then read the response to clear the standard event status register or (2) send the `*CLS` command to clear the status registers. Note that sending `*CLS` will also clear the error queue and operation complete status.

Generating an SRQ on calibration complete

An IEEE-488 bus SRQ (service request) can be used to detect operation complete instead of repeatedly polling the Model 2410. To use this method, send both *ESE 1 and *SRE 32 to the instrument, and then include the *OPC command at the end of each calibration command line, as previously described. Clear the SRQ by querying the ESR (using the *ESR? query) to clear OPC status, and then request the status byte with the *STB? query.

Refer to your controller's documentation for information on detecting and servicing SRQs.

C Calibration Programs

Introduction

This appendix includes a calibration program written in BASIC to help you calibrate the Model 2410, as well as an example program that demonstrates how to request calibration constants. Refer to Section 2 for more details on calibration procedures, equipment, and connections.

Computer hardware requirements

The following computer hardware is required to run the calibration programs:

- IBM PC compatible computer.
- Keithley KPC-488.2, KPS-488.2, or KPC-488.2AT; or CEC PC-488 IEEE-488 interface for the computer.
- Two shielded IEEE-488 connecting cables (Keithley Model 7007).

Software requirements

In order to use the calibration programs, you will need the following computer software:

- Microsoft QBasic (supplied with MS-DOS 5.0 or later).
- MS-DOS version 5.0 or later.
- HP-style Universal Language Driver, CECHP.EXE (supplied with Keithley and CEC interface cards listed above).

Calibration equipment

The following calibration equipment is required:

- Hewlett-Packard HP3458A Digital Multimeter

See Section 2 for detailed equipment specifications.

General program instructions

1. With the power off, connect the Model 2410 and the digital multimeter to the IEEE-488 interface of the computer. Be sure to use shielded IEEE-488 cables for bus connections. Also, connect the digital multimeter to the Model 2410 as discussed in Section 2.
2. Turn on the computer, the Model 2410, and the digital multimeter. Allow the Model 2410 and the multimeter to warm up for at least one hour before performing calibration.
3. Make sure the Model 2410 is set for a primary address of 24. (Use the front panel MENU/GPIB selection to check or change the address.)
4. Make sure the digital multimeter primary address is set to its factory default setting (22).
5. Make sure the computer bus driver software (CEHP.EXE) is properly initialized.
6. Enter the QBasic editor, and type in the following program. Check thoroughly for errors, and then save it using a convenient filename.
7. Run the program, and follow the prompts on the screen to perform calibration.

Program C-1. Model 2410 calibration program

```
' Model 2410 calibration program for use with the HP3458A Digital Multimeter.
' Rev. 1.0, 11/1/96
' 2410 primary address = 24. HP3458A primary address = 22.
OPEN "IEEE" FOR OUTPUT AS #1          ' Open IEEE-488 output path.
OPEN "IEEE" FOR INPUT AS #2          ' Open IEEE-488 input path.
PRINT #1, "INTERM CRLF"              ' Set input terminator.
PRINT #1, "OUTTERM LF"               ' Set output terminator.
PRINT #1, "REMOTE 22 24"             ' Put 2410, 3458A in remote.
PRINT #1, "CLEAR"                    ' Send DCL.
PRINT #1, "OUTPUT 24;*CLS"           ' Initialize 2410.
PRINT #1, "OUTPUT 24;*ESE 1;*SRE 32" ' Enable OPC and SRQ.
PRINT #1, "OUTPUT 22;PRESET NORM"    ' Initialize 3458A.
PRINT #1, "OUTPUT 22;NPLC 10;NDIG 7;TRIG LINE;FUNC DCV,AUTO"
,
CLS                                  ' Clear CRT.
PRINT "Model 2410 Calibration Program"
PRINT "Connect DMM volts input to Model 2410 INPUT/OUTPUT jacks."
GOSUB KeyCheck
FOR J = 1 TO 2                        ' Select volts/current cal.
IF J = 1 THEN
    RESTORE VoltsInit
    Max = 8
    Range = .2
    Limit = 1000
ELSE
    RESTORE CurrentInit
    Max = 4
    Range = .000001
    Limit = 1
    PRINT #1, "OUTPUT 24;:OUTP:STAT OFF"
    PRINT #1, "OUTPUT 22;FUNC DCI,AUTO"
    PRINT "Connect DMM current input to 2410 INPUT/OUTPUT jacks."
    GOSUB KeyCheck
END IF
Source = Range
FOR I = 1 TO Max: READ Cmd$: PRINT #1, "OUTPUT 24;"; Cmd$: NEXT I
WHILE Range <= Limit                  ' Cal all ranges.
IF J = 1 THEN RESTORE VoltsCal ELSE RESTORE CurrentCal
FOR I = 1 TO 12
    READ Cmd$
    SELECT CASE I
        CASE 1
            PRINT #1, "OUTPUT 24;"; Cmd$; Range
        CASE 2
            PRINT #1, "OUTPUT 24;"; Cmd$; -Source
            GOSUB ReadDMM
```



```
ErrCheck:                                ' Error check routine.
PRINT #1, "OUTPUT 24;:SYST:ERR?"         ' Query error queue.
PRINT #1, "ENTER 24"
INPUT #2, E, Err$
IF E <> 0 THEN PRINT Err$: GOTO EndProg ' Display error.
RETURN
'
ReadDMM:                                  ' Get reading from DMM.
SLEEP 5
PRINT #1, "ENTER 22"
INPUT #2, Reading$
RETURN
'
EndProg:                                   ' Close files, end program.
BEEP: PRINT "Calibration aborted."
PRINT #1, "OUTPUT 24;:CAL:PROT:LOCK"
PRINT #1, "OUTPUT 24;*RST"
PRINT #1, "LOCAL 22 24"
CLOSE
END
'
VoltsInit:                                ' Calibration command lists.
DATA "*RST",":SOUR:FUNC VOLT",":SENS:CURR:PROT 0.01"
DATA ":SENS:CURR:RANG 0.01",":SOUR:VOLT:PROT:LEV MAX",":SYST:RSEN OFF"
DATA ":CAL:PROT:CODE 'KI002410' ",":OUTP:STAT ON"
VoltsCal:
DATA ":SOUR:VOLT:RANG ",":SOUR:VOLT "
DATA ":CAL:PROT:SOUR ",":CAL:PROT:SENS ",":SOUR:VOLT 0.0"
DATA ":CAL:PROT:SOUR ",":CAL:PROT:SENS ",":SOUR:VOLT ",":CAL:PROT:SOUR "
DATA ":CAL:PROT:SENS ",":SOUR:VOLT 0.0",":CAL:PROT:SOUR "
CurrentInit:
DATA ":SOUR:FUNC CURR",":SENS:VOLT:PROT 20",":SENS:VOLT:RANG 20"
DATA ":OUTP:STAT ON"
CurrentCal:
DATA ":SOUR:CURR:RANG ",":SOUR:CURR ",":CAL:PROT:SOUR "
DATA ":CAL:PROT:SENS ",":SOUR:CURR 0.0",":CAL:PROT:SOUR ",":CAL:PROT:SENS "
DATA ":SOUR:CURR ",":CAL:PROT:SOUR ",":CAL:PROT:SENS "
DATA ":SOUR:CURR 0.0",":CAL:PROT:SOUR "
```

Requesting calibration constants

Program C-2 listed below demonstrates how to request the calibration constants from the Model 2410. The program requests and displays the calibration constants for all ranges of both the volts and current source and measurement functions.

Program C-2. Requesting calibration constants

```
' Example program to request calibration constants.
' Model 2410 primary address = 24
OPEN "IEEE" FOR OUTPUT AS #1           ' Open IEEE-488 output path.
OPEN "IEEE" FOR INPUT AS #2           ' Open IEEE-488 input path.
PRINT #1, "INTERM CRLF"               ' Set input terminator.
PRINT #1, "OUTTERM LF"                ' Set output terminator.
PRINT #1, "REMOTE 24"                 ' Put 2410 in remote.
PRINT #1, "OUTPUT 24;*RST"            ' Restore defaults.
CLS
PRINT #1, "OUTPUT 24;;SENS:FUNC:CONC OFF"
PRINT #1, "OUTPUT 24;;SENS:FUNC 'VOLT:DC'"
PRINT #1, "OUTPUT 24;;SOUR:FUNC VOLT"
PRINT #1, "OUTPUT 24;;CAL:PROT:CODE 'KI002410'" ' Unlock calibration.
Range = .2                             ' Initial range = 200mV.
PRINT "Model 2410 Voltage Calibration Constants:": PRINT
DO                                     ' Loop for all volts ranges.
    PRINT #1, "OUTPUT 24;;SOUR:VOLT:RANGE "; Range
    PRINT #1, "OUTPUT 24;;CAL:PROT:SENS:DATA?"
    PRINT #1, "ENTER 24"
    LINE INPUT #2, Data$
    PRINT Data$
    PRINT #1, "OUTPUT 24;;CAL:PROT:SOUR:DATA?"
    PRINT #1, "ENTER 24"
    LINE INPUT #2, Data$
    PRINT Data$
    Range = Range * 10
    IF Range = 200 THEN Range = 1000
LOOP WHILE Range <= 1000
PRINT #1, "OUTPUT 24;;CAL:PROT:LOCK"
PRINT #1, "OUTPUT 24;;SENS:FUNC 'CURR:DC'"
PRINT #1, "OUTPUT 24;;SOUR:FUNC CURR"
PRINT #1, "OUTPUT 24;;CAL:PROT:CODE 'KI002410'"
Range = .000001                         ' Initial range = 1uA.
PRINT : PRINT "Model 2410 Current Calibration Constants:": PRINT
DO                                     ' Loop for all current ranges.
    PRINT #1, "OUTPUT 24;;SOUR:CURR:RANGE "; Range
    PRINT #1, "OUTPUT 24;;CAL:PROT:SENS:DATA?"
    PRINT #1, "ENTER 24"
    LINE INPUT #2, Data$
```

```
PRINT Data$
PRINT #1, "OUTPUT 24;:CAL:PROT:SOUR:DATA?"
PRINT #1, "ENTER 24"
LINE INPUT #2, Data$
PRINT Data$
Range = Range * 10
IF Range > .009 AND Range < .011 THEN Range = .02
IF Range > .19 AND Range < .21 THEN Range = .1
LOOP WHILE Range <= 1
PRINT #1, "OUTPUT 24;:CAL:PROT:LOCK"      ' Lock out calibration.
PRINT #1, "OUTPUT 24;*RST"
PRINT #1, "LOCAL 24"
CLOSE
END
```

Index

A

Accuracy calculations A-2
Analog board removal 5-6
Analog circuitry checks 4-16
Assembly drawings 5-4

B

Battery replacement 4-17

C

Calibration 2-1
Calibration considerations 2-4
Calibration equipment C-3
Calibration programs C-1
Case cover removal 5-5
Command reference B-1
Command summary B-2
Compliance considerations 1-9
Component layouts 6-3
Computer hardware requirements C-2
Current measurement accuracy 1-16

D

Detecting calibration errors B-11
Detecting calibration step completion B-13
Digital board removal 5-7
Disassembly 5-1

E

Environmental conditions 2-3

F

Factory service 6-3
Front panel calibration 2-9
Front panel disassembly 5-8
Front panel tests 4-3

G

General program instructions C-3

H

Handling and cleaning 5-2

I

Instrument re-assembly 5-10

L

Line fuse replacement 3-2

M

Miscellaneous commands B-3

N

No comm link error 4-18

O

Ordering information 6-2
Output current accuracy 1-14
Output voltage accuracy 1-11

P

Parts lists 6-2
Performance verification 1-1
Performing the verification test procedures 1-7
Power-on self-test 4-2
Principles of operation 4-5

R

Remote calibration 2-16
Removing power components 5-9
Repair considerations 4-2
Replaceable parts 6-1
Requesting calibration constants C-7
Resistance measurement accuracy 1-17
Restoring factory defaults 1-6
Routine maintenance 3-1

S

Single-range calibration 2-24
Software requirements C-2
Specifications A-1
Static sensitive devices 5-3

T

Troubleshooting 4-1, 4-13

V

Verification test requirements 1-3
Voltage measurement accuracy 1-13

Specifications are subject to change without notice.
All Keithley trademarks and trade names are the property of Keithley Instruments.
All other trademarks and trade names are the property of their respective companies.

Keithley Instruments

Corporate Headquarters • 28775 Aurora Road • Cleveland, Ohio 44139 • 440-248-0400 • 1-800-833-9200 • www.tek.com/keithley

